



Office of the City Manager

INFORMATION CALENDAR
May 12, 2020

To: Honorable Mayor and Members of the City Council
 From: Dee Williams-Ridley, City Manager
 Submitted by: Timothy Burroughs, Director, Planning and Development Department
 Subject: LPO NOD: 2133 University Avenue/#LMSA2019-0001

INTRODUCTION

The attached Landmarks Preservation Commission Notice of Decision (NOD) is presented to the Mayor and City Council pursuant to Berkeley Municipal Code/Landmarks Preservation Ordinance (BMC/LPO) Section 3.24.240.A, which requires that “a copy of the Notice of Decision shall be filed with the City Clerk, and the City Clerk shall present said copy to the City Council at its next regular meeting.”

CURRENT SITUATION AND ITS EFFECTS

The Landmark Preservation Commission (LPC/Commission) has approved a Structural Alteration Permit (SAP) for a signage program the subject City Landmark site. This action is subject to a 15-day appeal period, which began on April 27, 2020.

BACKGROUND

BMC/LPO Section 3.24.300 allows City Council to review any action of the Landmarks Preservation Commission in granting or denying a Structural Alteration Permit. In order for Council to review the decision on its merits, Council must appeal the Notice of Decision. To do so, a Council member must move this Information Item to Action and then move to set the matter for hearing on its own. Such action must be taken within 15 days of the mailing of the Notice of Decision, or by May 12, 2020. Such certification to Council shall stay all proceedings in the same manner as the filing of an appeal.

If the Council chooses to appeal the action of the Commission, then a public hearing will be set. The Council must rule on the application within 30 days of closing the hearing, otherwise the decision of the Commission is automatically deemed affirmed.

Unless the Council wishes to review the determination of the Commission and make its own decision, the attached NOD is deemed received and filed.

ENVIRONMENTAL SUSTAINABILITY

Landmark designation provides opportunities for the adaptive re-use and rehabilitation of historic resources within the City. The rehabilitation of these resources, rather than their removal, achieves construction and demolition waste diversion, and promotes investment in existing urban centers.

POSSIBLE FUTURE ACTION

The Council may choose to appeal the decision, in which case it would conduct a public hearing at a future date.

FISCAL IMPACTS OF POSSIBLE FUTURE ACTION

There are no known fiscal impacts associated with this action.

CONTACT PERSON

Fatema Crane, Landmarks Preservation Commission Secretary, Planning and Development, 510-981-7410

Attachments:

1: Notice of Decision – #LMSA 2019-0001, 2133 University Avenue



L A N D M A R K S
P R E S E R V A T I O N
C O M M I S S I O N

N O T I C E O F D E C I S I O N

DATE OF BOARD DECISION: March 5, 2020
DATE NOTICE MAILED: April 27, 2020
APPEAL PERIOD EXPIRATION: May 12, 2020
EFFECTIVE DATE OF PERMIT (Barring Appeal or Certification): May 13, 2020¹

2133 University Avenue

Landmarks Sign Alteration Permit (#LMSA2019-0001) to establish a sign program for the buildings and tenant spaces within the Acheson Commons development project that contains three City of Berkeley Landmark buildings: the Acheson Physicians' Building, the MacFarlane Building, and the Sill's Grocery & Hardware Company Building.

The Landmarks Preservation Commission of the City of Berkeley, after conducting a public hearing, **APPROVED** the following permit:

PERMITS REQUIRED:

- Structural Alteration Permit, pursuant to Berkeley Municipal Code Section 3.24.200

APPLICANT: Paulina Paczkowska, Signage Designer

ZONING DISTRICT: Downtown Commercial/Mixed Use (C-D/MU)

ENVIRONMENTAL REVIEW STATUS: Categorically exempt pursuant to Section 15331 of the CEQA Guidelines for Historical Resource Rehabilitation.

The Zoning Application and application materials for this project is available online at:

¹ Pursuant to BMC Section 23B.32.090, the City Council may "certify" any decision of the LPC for review, which has the same effect as an appeal. In most cases, the Council must certify the LPC decision during the 14-day appeal period. However, pursuant to BMC Section 1.04.070, if any portion of the appeal period falls within a Council recess, the deadline for Council certification is suspended until the first Council meeting after the recess, plus the number of days of the appeal period that occurred during the recess, minus one day. If there is no appeal or certification, the Use Permit becomes effective the day after the certification deadline has passed.

LANDMARKS PRESERVATION COMMISSION
 NOTICE OF DECISION
 Landmarks Signage Application - #LMSA2019-0001
 2133 University Avenue – Acheson Commons
 April 27, 2020
 Page 2 of 5

<http://www.cityofberkeley.info/zoningapplications>

FINDINGS, CONDITIONS AND APPROVED PLANS ARE ATTACHED TO THIS NOTICE

BOARD VOTE: 8-0-1-0

YES: ABRANCHES DA SILVA, ADAMS, ALLEN, CRANDALL, ENCHILL, LACEY, MONTGOMERY, SCHWARTZ

NO: None

ABSTAIN: JOHNSON

ABSENT: None

Note New Methods for Submitting Appeals during Shelter-In-Place Order

TO APPEAL THIS DECISION (see Section 3.24.300 of the Berkeley Municipal Code):

To appeal a decision of the Landmarks Preservation Commission to the City Council during the 2020 City Council Shelter-In-Place Order, you must:

1. Mail a letter clearly and concisely setting forth the grounds for the appeal with a check or money order for required fees to the City Clerk, located at 2180 Milvia Street, 1st Floor, Berkeley, 94704. The City Clerk's telephone number is (510) 981-6900.

OR

Alternatively, you may email your complete appeal and all attachments to the Planning Department at planning@cityofberkeley.info and include a telephone number where you can be reached during the day. Planning Department staff will call you within three business days to obtain payment information for the required fees by credit card *only*.

- a. Pursuant to BMC Section 3.24.300.A, an appeal may be taken to the City Council by the application of the owners of the property or their authorized agents, or by the application of at least fifty residents of the City aggrieved or affected by any determination of the commission made under the provisions of Chapter 3.24.
2. Submit the required fee (checks and money orders must be payable to 'City of Berkeley'):
 - a. The basic fee for persons other than the applicant is \$500. This fee may be reduced to \$100 if the appeal is signed by persons who lease or own at least 50 percent of the parcels or dwelling units within 300 feet of the project site, or at least 25 such persons (not including dependent children), whichever is less. Signatures collected

LANDMARKS PRESERVATION COMMISSION
 NOTICE OF DECISION
 Landmarks Signage Application - #LMSA2019-0001
 2133 University Avenue – Acheson Commons
 April 27, 2020
 Page 3 of 5

per the filing requirement in BMC Section 3.24.300.A may be counted towards qualifying for the reduced fee, so long as the signers are qualified. The individual filing the appeal must clearly denote which signatures are to be counted towards qualifying for the reduced fee.

- b. The fee for appeals of affordable housing projects (defined as projects which provide 50 percent or more affordable units for households earning 80% or less of Area Median Income) is \$500, which may not be reduced.
 - c. The fee for all appeals by Applicants is \$2500.
3. The appeal must be received prior to 5:00 p.m. on the "APPEAL PERIOD EXPIRATION" date shown above (if the close of the appeal period falls on a weekend or holiday, then the appeal period expires the following business day).

If no appeal is received, the landmark designation will be final on the first business day following expiration of the appeal period.

NOTICE CONCERNING YOUR LEGAL RIGHTS:

If you object to this decision, the following requirements and restrictions apply:

1. If you challenge this decision in court, you may be limited to raising only those issues you or someone else raised at the public hearing described in this notice, or in written correspondence delivered to the Landmarks Preservation Commission at, or prior to, the public hearing.
2. You must appeal to the City Council within fifteen (15) days after the Notice of Decision of the action of the Landmarks Preservation Commission is mailed. It is your obligation to notify the Land Use Planning Division in writing of your desire to receive a Notice of Decision when it is completed.
3. Pursuant to Code of Civil Procedure Section 1094.6(b) and Government Code Section 65009(c)(1), no lawsuit challenging a City Council decision, as defined by Code of Civil Procedure Section 1094.6(e), regarding a use permit, variance or other permit may be filed more than ninety (90) days after the date the decision becomes final, as defined in Code of Civil Procedure Section 1094.6(b). Any lawsuit not filed within that ninety (90) day period will be barred.
4. Pursuant to Government Code Section 66020(d)(1), notice is hereby given to the applicant that the 90-day protest period for any fees, dedications, reservations, or other exactions included in any permit approval begins upon final action by the City, and that any challenge must be filed within this 90-day period.
5. If you believe that this decision or any condition attached to it denies you any reasonable economic use of the subject property, was not sufficiently related to a legitimate public purpose, was not sufficiently proportional to any impact of the project, or for any other reason constitutes a "taking" of property for public use without just compensation under the California or United States Constitutions, your appeal of this decision must including the following information:

LANDMARKS PRESERVATION COMMISSION
NOTICE OF DECISION
Landmarks Signage Application - #LMSA2019-0001
2133 University Avenue – Acheson Commons
April 27, 2020
Page 4 of 5

- A. That this belief is a basis of your appeal.
- B. Why you believe that the decision or condition constitutes a "taking" of property as set forth above.
- C. All evidence and argument in support of your belief that the decision or condition constitutes a "taking" as set forth above.

If you do not do so, you will waive any legal right to claim that your property has been taken, both before the City Council and in court.

PUBLIC COMMENT:

Communications to Berkeley boards, commissions or committees are public record and will become part of the City’s electronic records, which are accessible through the City’s website. **Please note: e-mail addresses, names, addresses, and other contact information are not required, but if included in any communication to a City board, commission or committee, will become part of the public record.** If you do not want your e-mail address or any other contact information to be made public, you may deliver communications via U.S. Postal Service or in person to the secretary of the relevant board, commission or committee. If you do not want your contact information included in the public record, please do not include that information in your communication. Please contact the secretary to the relevant board, commission or committee for further information.

FURTHER INFORMATION:

Questions about the project should be directed to the project planner, Fatema Crane, at (510) 981-7410 or fcrane@cityofberkeley.info. All project application materials, including full-size plans, may be viewed at the Permit Service Center (Zoning counter), 1947 Center Street, 3rd Fl., between 8 a.m. and 4 p.m., Monday through Friday, except Tuesday when the Center closes at 3PM.

ATTACHMENTS:

- 1. Findings and Conditions
- 2. Project Plans



ATTEST: _____
Fatema Crane, Secretary
Landmarks Preservation Commission

LANDMARKS PRESERVATION COMMISSION
NOTICE OF DECISION
Landmarks Signage Application - #LMSA2019-0001
2133 University Avenue – Acheson Commons
April 27, 2020
Page 5 of 5

cc:

City Clerk

Applicant: Paulina Paczkowska, 235 Pine Street, Suite 2100, San Francisco, CA 94101

Property Owner: MCREF Acheson LLC, 411 Borel Avenue, Suite 405, San Mateo, CA 94402

Steven Finacom, 2308 Russell Street, Berkeley, CA 94705

ATTACHMENT 1, PART 2

FINDINGS AND CONDITIONS

2133 University – Acheson Commons

Signage Alteration Permit #LMSA2019-0001

To establish a sign program for the buildings and tenant spaces within the Acheson Commons development project that contains three City of Berkeley Landmark buildings: the Acheson Physicians' Building, the MacFarlane Building, and the Sill's Grocery & Hardware Company Building.

CEQA FINDINGS

The project is categorically exempt from the provisions of the California Environmental Quality Act (CEQA, Public Resources Code §21000, et seq. and California Code of Regulations, §15000, et seq.) pursuant to Section 15331 of the CEQA Guidelines ("Historic Resource Restoration/Rehabilitation"). Furthermore, none of the exceptions in CEQA Guidelines Section 15300.2 apply, as follows: (a) the site is not located in an environmentally sensitive area, (b) there are no cumulative impacts, (c) there are no significant effects, (d) the project is not located near a scenic highway, (e) the project site is not located on a hazardous waste site pursuant to Government Code Section 65962.5, and (f) the project will not affect any historical resource.

SECRETARY OF THE INTERIOR'S STANDARDS FINDINGS

Regarding the Secretary of the Interior's Standards for Rehabilitation, the Landmarks Preservation Commission of the City of Berkeley makes the following findings:

1. The approved Acheson Commons development retains the historic ground floor commercial uses at this site. The new signage program would require minimal change to distinctive materials, features, spaces, and spatial relationships that characterize this site.
2. The proposal to establish a signage program for the tenant spaces at this project site would not result in removal of distinctive materials or alterations that would significantly change the overall spatial relations that characterize the building (e.g. building mass and height; storefront features and trim pieces).
3. Owing to their contemporary design and selection of materials, the proposed signage, would be recognizable as present-day elements of the building and would not be confused as original or historic, nor would they create a false sense of history.
4. The proposed signage would not affect any changes to the property that have acquired historic significance in their own right.
5. No distinctive materials, features, finishes or techniques will be affected by this proposal.

6. Due to the rehabilitation currently underway, no deteriorated historic features would be affected by this request and none are proposed to be replaced.
7. If approved, this project will be subject to a condition that ensures only the gentlest measures are employed when chemical treatments are required.
8. Because no excavation will be required for the proposed alteration of this building, any existing archeological resources at this site will be unaffected by this proposal.
9. The proposed exterior alterations would not destroy features and spatial relationships that characterize the subject property, as described previously in the Analysis for SOI Standard 2, above.
10. The new signage would not alter the overall form of the building. If the new signage were removed in the future, the essential form and integrity of the historic property and its environment would be unimpaired.

LANDMARK PRESERVATION ORDINANCE FINDINGS

As required by Section 3.24.260 of the Landmarks Preservation Ordinance, the Commission finds that proposed work is appropriate for and consistent with the purposes of the Ordinance, and will preserve and enhance the characteristics and features specified in the designation for this property. Specifically:

1. The proposal maintains the form and scale of the historic buildings and storefronts.
2. The proposed work will not adversely affect the exterior architectural features of the Landmark buildings, the special character or historical, architectural or aesthetic interest or value of the site because the new signage is carefully fit within the finer building details and trim pieces, or to maintain a limited profile when protecting from the building façade. The sign will neither diminish nor conflict with the integrity of the three landmark buildings within the Acheson Commons development project site. The overall sign program provides for consistency with signage on the new development that abuts and surrounds the historic buildings.

STANDARD CONDITIONS

The following conditions, as well as all other applicable provisions of the Landmarks Preservation Ordinance, apply to this Permit:

1. Conditions Shall be Printed on Plans

The conditions of this Permit shall be printed on the *second* sheet of each plan set submitted for a building permit pursuant to this Permit, under the title 'Structural Alteration Permit Conditions'. *Additional sheets* may also be used if the *second* sheet is not of sufficient size to list all of the conditions. The sheet(s) containing the conditions shall be of the same size as those sheets containing the construction drawings; 8-1/2" by 11" sheets are not acceptable.

2. Plans and Representations Become Conditions

Except as specified herein, the site plan, floor plans, building elevations and/or any additional information or representations, whether oral or written, indicating the proposed structure or manner of operation submitted with an application or during the approval process are deemed conditions of approval.

3. Subject to All Applicable Laws and Regulations

The approved use and/or construction is subject to, and shall comply with, all applicable City Ordinances and laws and regulations of other governmental agencies. Prior to construction, the applicant shall identify and secure all applicable permits from the Building and Safety Division, Public Works Department and other affected City divisions and departments.

4. Exercise and Lapse of Permits (Section 23B.56.100)

B. A permit for the construction of a building or structure is deemed exercised when a valid City building permit, if required, is issued, and construction has lawfully commenced.

A. A permit may be declared lapsed and of no further force and effect if it is not exercised within one year of its issuance, except that permits for construction or alteration of structures or buildings may not be declared lapsed if the permittee has: (1) applied for a building permit; or, (2) made substantial good faith efforts to obtain a building permit and begin construction, even if a building permit has not been issued and/or construction has not begun.

5. Indemnification Agreement

The applicant shall hold the City of Berkeley and its officers harmless in the event of any legal action related to the granting of this Permit, shall cooperate with the City in defense of such action, and shall indemnify the City for any award of damages or attorneys fees that may result.

ADDITIONAL CONDITIONS

The following additional conditions are attached to this Permit:

- 6. Chemical Treatments.** Any chemical treatments needed as construction progresses will be undertaken using the gentlest means possible.
- 7. Anchors.** Anchors in the historical façade shall be as discreet as possible and patched when signage or awnings are removed.
- 8. Lighting.** All exterior lighting, including for signage, shall be shielded and directed downward and away from property lines to prevent excessive glare beyond the subject property.
- 9. Signage Program details.** Prior to staff approval of any building permits for this signage program, the applicant shall submit: complete sections and installation details for all approved signage installations; colors and materials information; and signage

and lettering heights, dimensions, placement on building(s). All materials shall be matte unless otherwise noted.

10. **Signage for Ace/Sills Building & MacFarlane Building.** Prior to issuance of any building permits for this signage program, staff shall review and approve final details and section drawings for signage on the historic building storefronts in the Ace/Sills Building and the MacFarlane Building, and staff may require a reduction in wall signage lettering, including height and depth.
 11. **Modera/Acheson Commons Building Signage.** Building signage shall be limited to two banner-style blade signs: one located on the Shattuck Avenue façade and placed near southwest corner of the MacFarlane Building, and one on the University façade and placed near the southeast corner of the Ace/Sills Building.
- AT ALL TIMES**
12. The property owner shall maintain all buildings and storefronts in good repair and remove building and tenant signage upon vacancy.



MODERA®

BY MILL CREEK

DESIGN DEVELOPMENT

MODERA ACHESON COMMONS
SIGNAGE & WAYFINDING

02.06.2020



Table of contents

Project Overview

Property Location

Sign Location Plan

Building Exterior Signage

Commercial Frontage Signage System

Exterior Wayfinding

Design

Project Addresses

- 1979 - 1987 Shattuck Avenue
- 2101 - 2113 University Avenue
- 2125 - 2145 University Avenue
- 1922 - 1930 Walnut Street

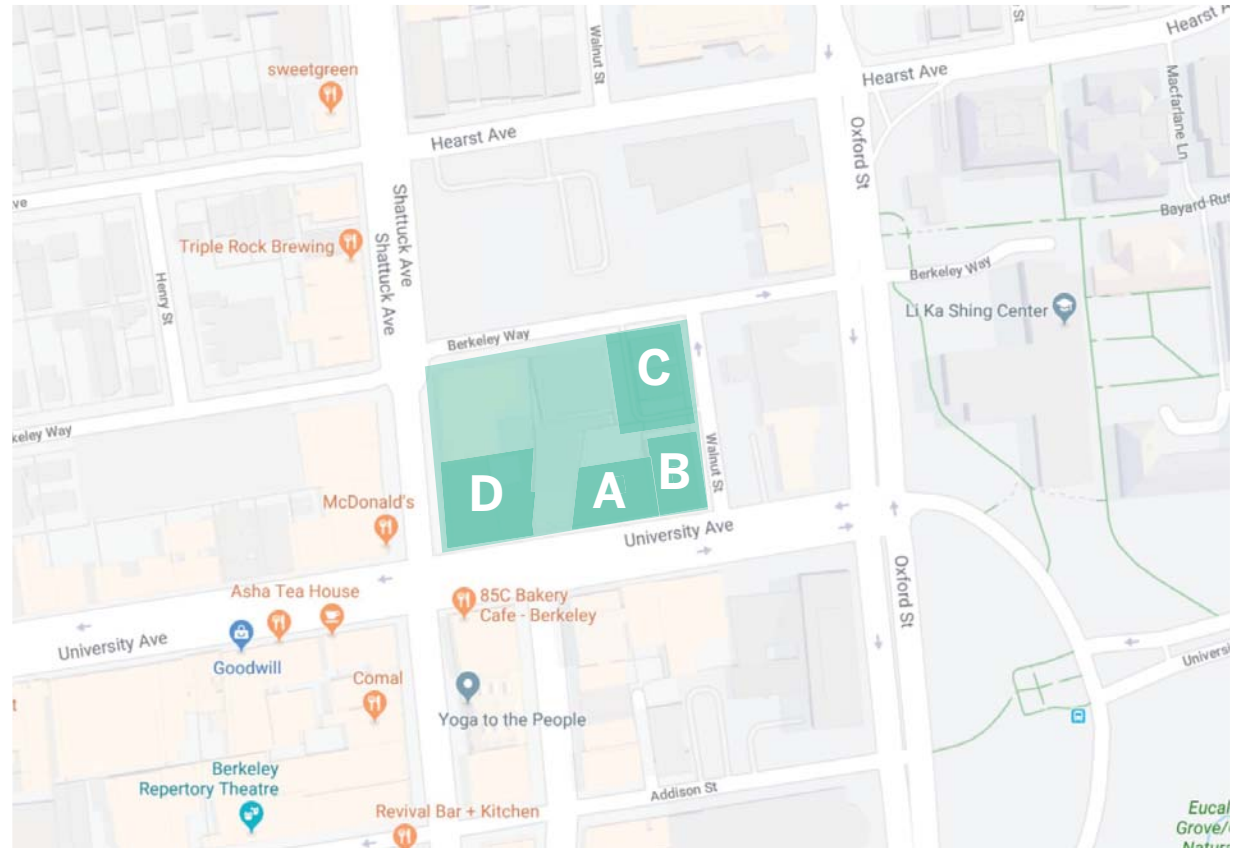

Buildings, Exterior



Building D — MACFARLANE & KRISHNA



Building A — ACHESON / PHYSICIANS BUILDING



Building C — WALNUT



Building B — ACE

Project Overview

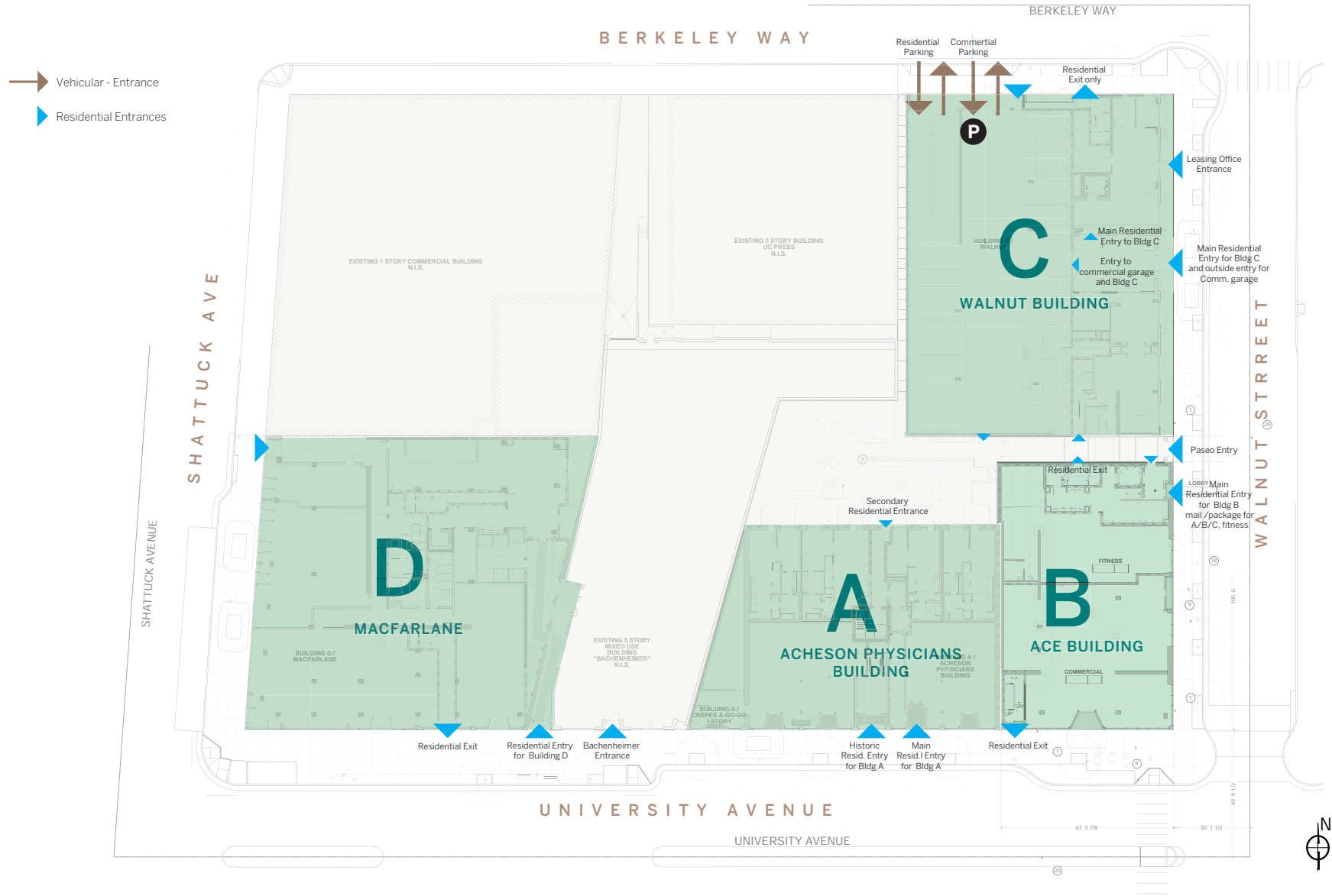

Moderera Acheson Commons

Berkeley, CA

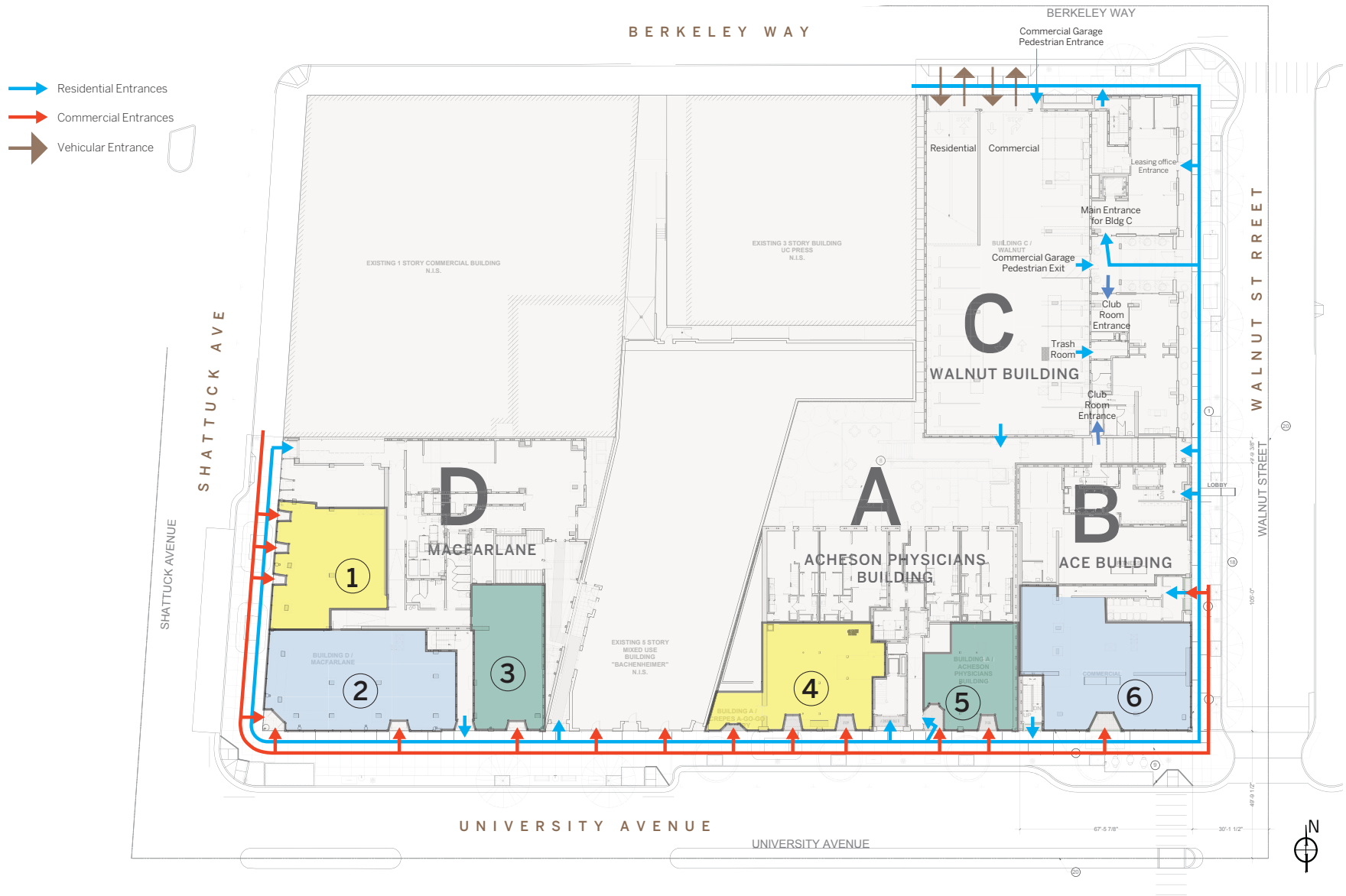

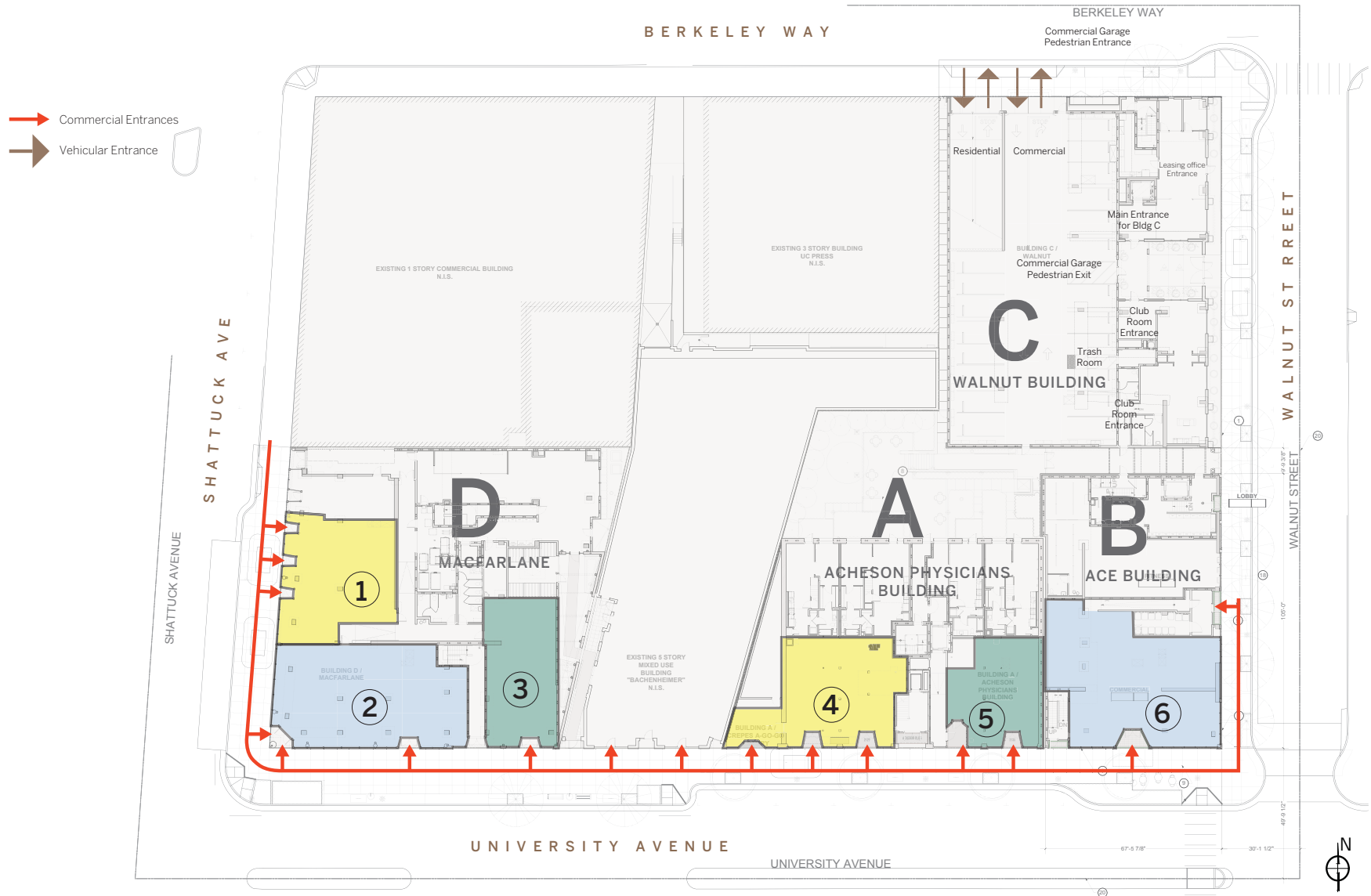



 Commercial Entrances
 Vehicular Entrance

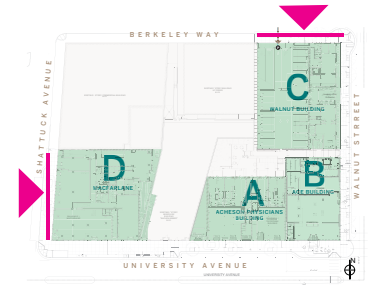

WEST FRONTAGE Elevation
Building D — MACFARLANE & KRISHNA



NORTH FRONTAGE Elevation
Building C — WALNUT

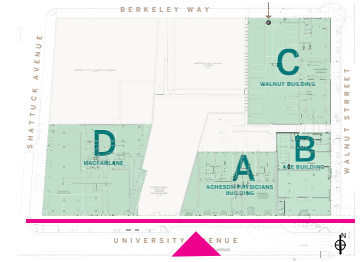

SOUTH FRONTAGE Elevation

Building D — MACFARLANE & KRISHNA

Building A — ACHESON / PHYSICIANS BUILDING

Building B — ACE

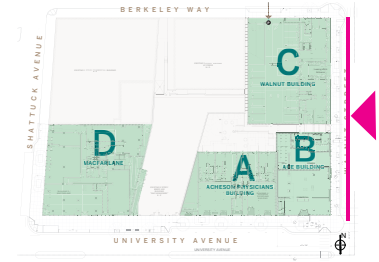

EAST FRONTAGE Elevation
Building B — ACE

Building C — WALNUT

Sign Location Plan

Moderer Acheson Commons

Berkeley, CA

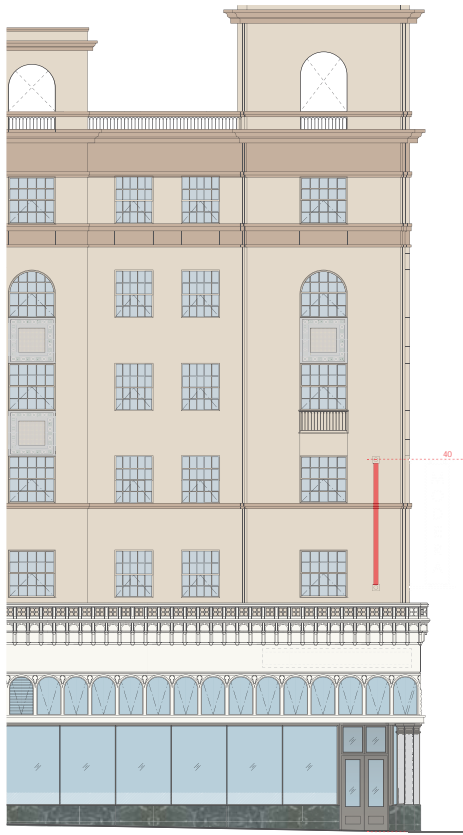
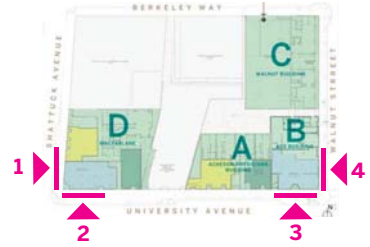

1) Building D — MACFARLANE (WEST)

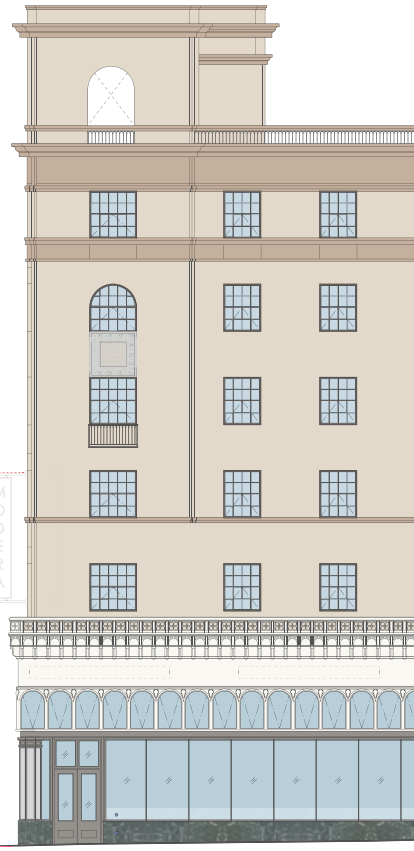

2) Building D — MACFARLANE (SOUTH)



3) Building B — ACE BUILDING (SOUTH)



4) Building B — ACE BUILDING (EAST)

Building D — MACFARLANE & KRISHNA (WEST)

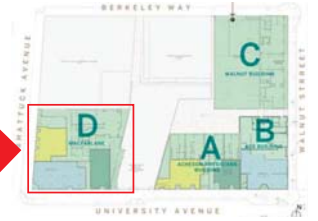

Allowable signs per commercial tenant:
 On premises with one street frontage, any **combination of two (2) of the following:**
 one wall sign, one projecting sign, one ground sign, one roof sign, one marquee sign, one moving sign.

On premises with more than one street frontage, for each additional street frontage any combination of two of the following: one wall sign, one projecting sign, one marquee sign, one moving sign.

- Sign location area
- Alternative sign location area
- Storefront Sign
- Blade Sign (N/A)
- Window Graphic/max area
- Window Graphic/ Direct. info
- Street Number
- Wayfinding Plaque

Coordinate the design and alignment of signs on multiple use buildings in order to achieve a unified appearance rather than visual confusion.



Building ID Sign

SIGN AREA
 The size of signs and sign letters should be typically between 6 and 16 inches high. Maximum height should not exceed 2 feet, although signs with dimensional letters only are strongly encouraged. Primary signs should contain only the name of the business and/or its logo. Cabinet signs are strongly discouraged.

WINDOW SIGNS should not exceed 15% of the window area so that visibility into and out of the window is not obstructed.

Building D — MACFARLANE & KRISHNA (SOUTH)

Allowable signs per commercial tenant:
 On premises with one street frontage, any combination of **two (2)** of the following:
 one wall sign, one projecting sign, one ground sign, one roof sign, one marquee sign, one moving sign.

On premises with more than one street frontage, for each additional street frontage any combination of two of the following: one wall sign, one projecting sign, one marquee sign, one moving sign.

- Sign location area
- Alternative sign location area
- Storefront Sign
- Blade Sign (N/A)
- Window Graphic/max area
- Window Graphic/ Direct. info
- Street Number
- Wayfinding Plaque

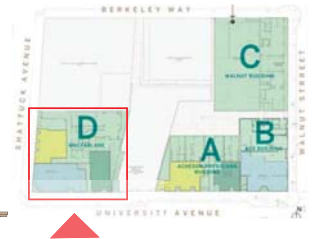

SIGN AREA
 The size of signs and sign letters should be typically between 6 and 16 inches high. Maximum height should not exceed 2 feet, although signs with dimensional letters only are encouraged. Primary signs should contain only the name of the business and/or its logo. Cabinet signs are strongly discouraged.

Coordinate the design and alignment of signs on multiple use buildings in order to achieve a unified appearance rather than visual confusion.

SIGN AREA – TRANSOM
 The size of signs and sign letters should be between 6 and 13 inches high. Please see pages 56–58 for sign types.

Window signs should not exceed 15% of the window area so that visibility into and out of the window is not obstructed.

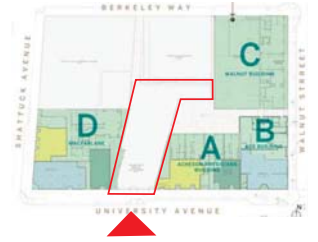

Allowable signs per commercial tenant:
 On premises with one street frontage, any combination of **two (2)** of the following:
 one wall sign, one projecting sign, one ground sign, one roof sign, one marquee sign, one moving sign.

- Sign location area
- Alternative sign location area
- Storefront Sign
- Blade Sign (N/A)
- Window Graphic/max area
- Window Graphic/ Direct. info
- Street Number
- Wayfinding Plaque

Coordinate the design and alignment of signs on multiple use buildings in order to achieve a unified appearance rather than visual confusion.

SIGN AREA
 The size of signs and sign letters should be typically between 6 and 16 inches high. Maximum height should not exceed 2 feet, although signs with dimensional letters only are encouraged. Primary signs should contain only the name of the business and/or its logo. Cabinet signs are strongly discouraged.

Window signs should not exceed 15% of the window area so that visibility into and out of the window is not obstructed.

Building A — ACHESON / PHYSICIANS BUILDING

Allowable signs per commercial tenant:
 On premises with one street frontage, any combination of **two (2) of the following:**
 one wall sign, one projecting sign, one ground sign, one roof sign, one marquee sign, one moving sign.

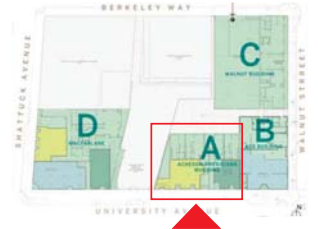

- Sign location area
- Alternative sign location area
- Storefront Sign
- Blade Sign
- Window Graphic/max area
- Window Graphic/ Direct. info
- Street Number
- Wayfinding Plaque

Coordinate the design and alignment of signs on multiple use buildings in order to achieve a unified appearance rather than visual confusion.

SIGN AREA - TRANSOM
 The size of signs and sign letters should be between 6 and 13 inches high. Please see pages 56–58 for sign types.

SIGN AREA
 The size of signs and sign letters should be between 6 and 16 inches high. Dimensional letters only are encouraged. Primary signs should contain only the name of the business and/or its logo. Cabinet signs are strongly discouraged.

Window signs should not exceed 15% of the window area so that visibility into and out of the window is not obstructed.





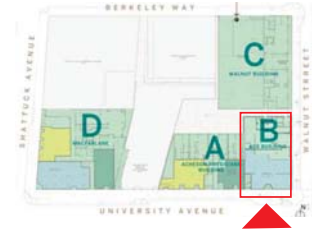







Building B — ACE BUILDING



Allowable signs per commercial tenant:
 On premises with one street frontage, any **combination of two (2) of the following:** one wall sign, one projecting sign, one ground sign, one roof sign, one marquee sign, one moving sign.

On premises with more than one street frontage, for each additional street frontage any combination of two of the following: one wall sign, one projecting sign, one marquee sign, one moving sign.

-   Storefront Sign
-   Blade Sign
-   Window Graphic/max area
-   Window Graphic/ Direct. info
-  Street Number
-  Wayfinding Plaque

Coordinate the design and alignment of signs on multiple use buildings in order to achieve a unified appearance rather than visual confusion.











SIGN AREA - TRANSOM
 The size of signs and sign letters should be between 6 and 13 inches high. Please see pages 56–58 for sign types.

Window signs should not exceed 15% of the window area so that visibility into and out of the window is not obstructed.

Building B — ACE BUILDING (EAST)

Allowable signs per commercial tenant:
 On premises with one street frontage, any combination of **two (2)** of the following:
 one wall sign, one projecting sign, one ground sign, one roof sign, one marquee sign, one moving sign.

On premises with more than one street frontage, for each additional street frontage any combination of two of the following:
 one wall sign, one projecting sign, one marquee sign, one moving sign.

-   Storefront Sign
-   Blade Sign
-   Window Graphic/max area
-   Window Graphic/ Direct. info
-  Street Number
-  Wayfinding Plaque

Coordinate the design and alignment of signs on multiple use buildings in order to achieve a unified appearance rather than visual confusion.

SIGN AREA - TRANSOM
 The size of signs and sign letters should be between 6 and 13 inches high.
 Please see pages 56–58 for sign types.

Window signs should not exceed 15% of the window area so that visibility into and out of the window is not obstructed.



Main Residential Entrance
 to Bldg B, Mail, Package for
 A/B/C, Fitness

Courtyard Entrance

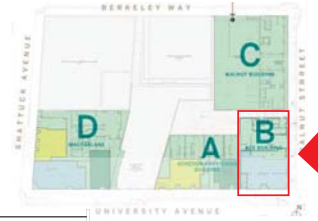



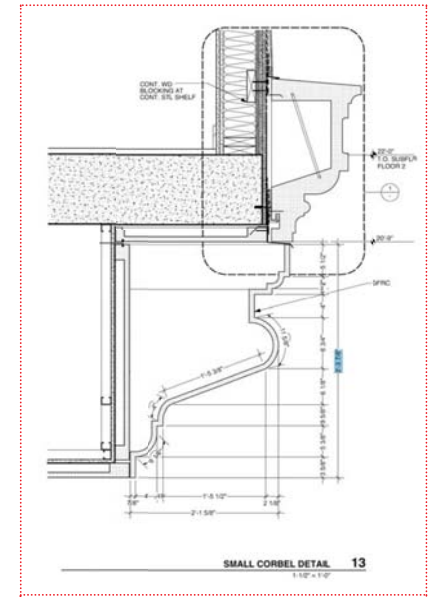

PARKING BLADE SIGN
(VEHICULAR, PEDESTRIAN)

PARKING ENTRY SIGN
(PEDESTRIAN)

PARKING ENTRY SIGN
(VEHICULAR, PEDESTRIAN)

← → Two way street

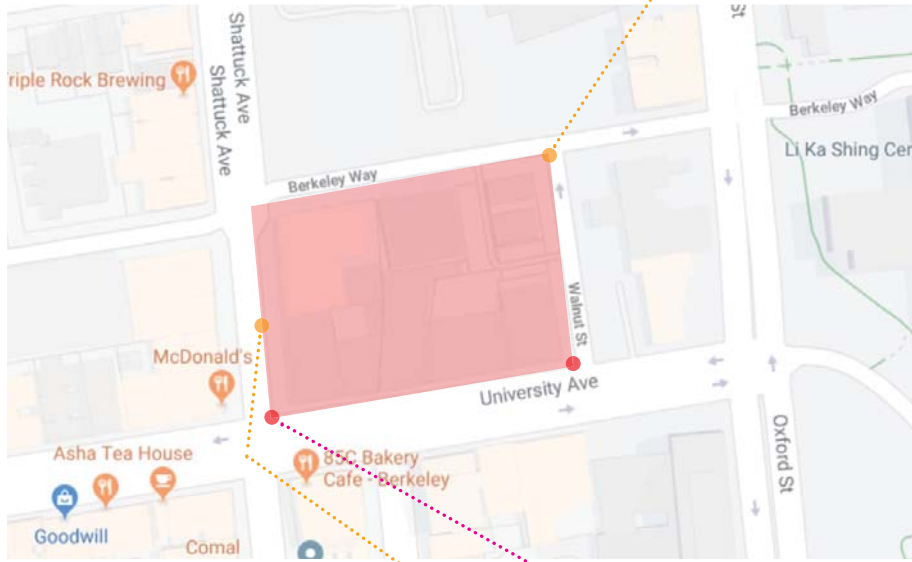

- Building ID - primary locations
- Building ID - secondary locations

PLEASE SEE DETAILS - PAGES 27-33



Building D — MACFARLANE



Building B — ACE

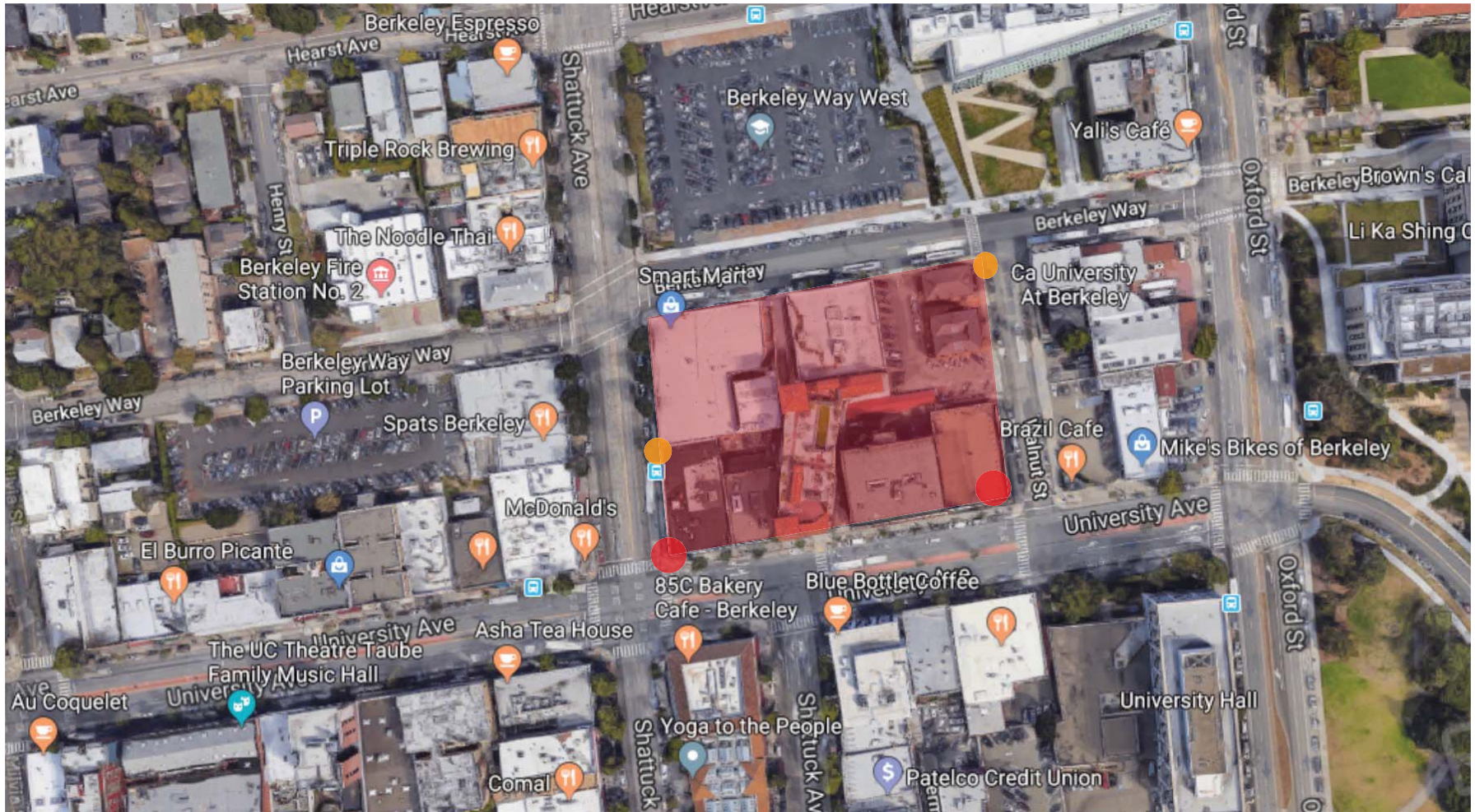

● Building ID - primary locations ● Building ID - secondary locations

Design

Design Direction – Spanish Revival

Moderata Acheson Commons
Berkeley, CA



LOOK & FEEL / MATERIAL & COLOR

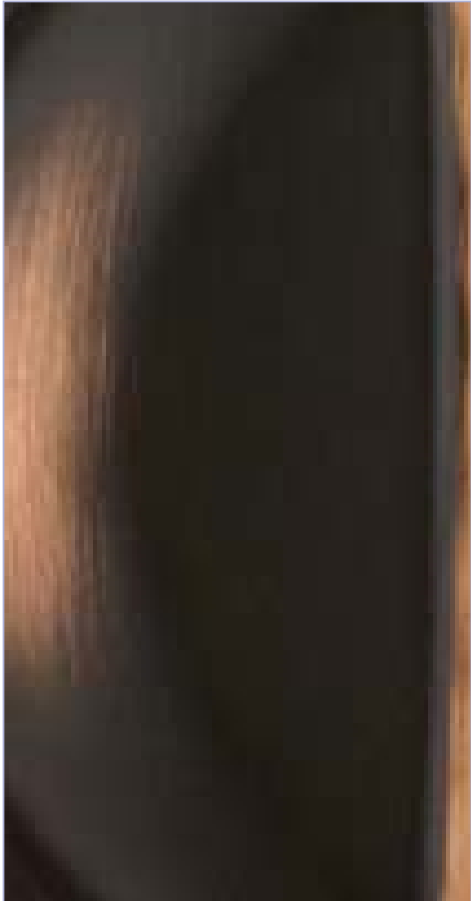

OILED RUBBED BRONZE



METALWORK

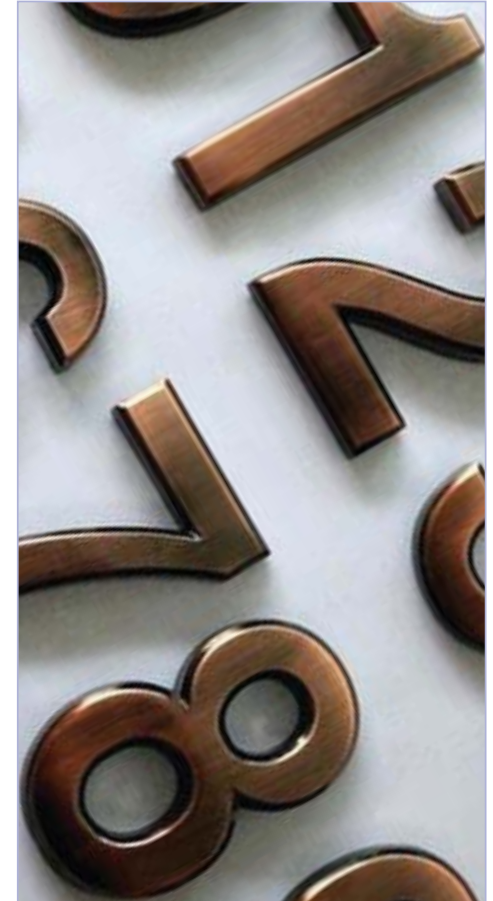

BRONZE LETTERING

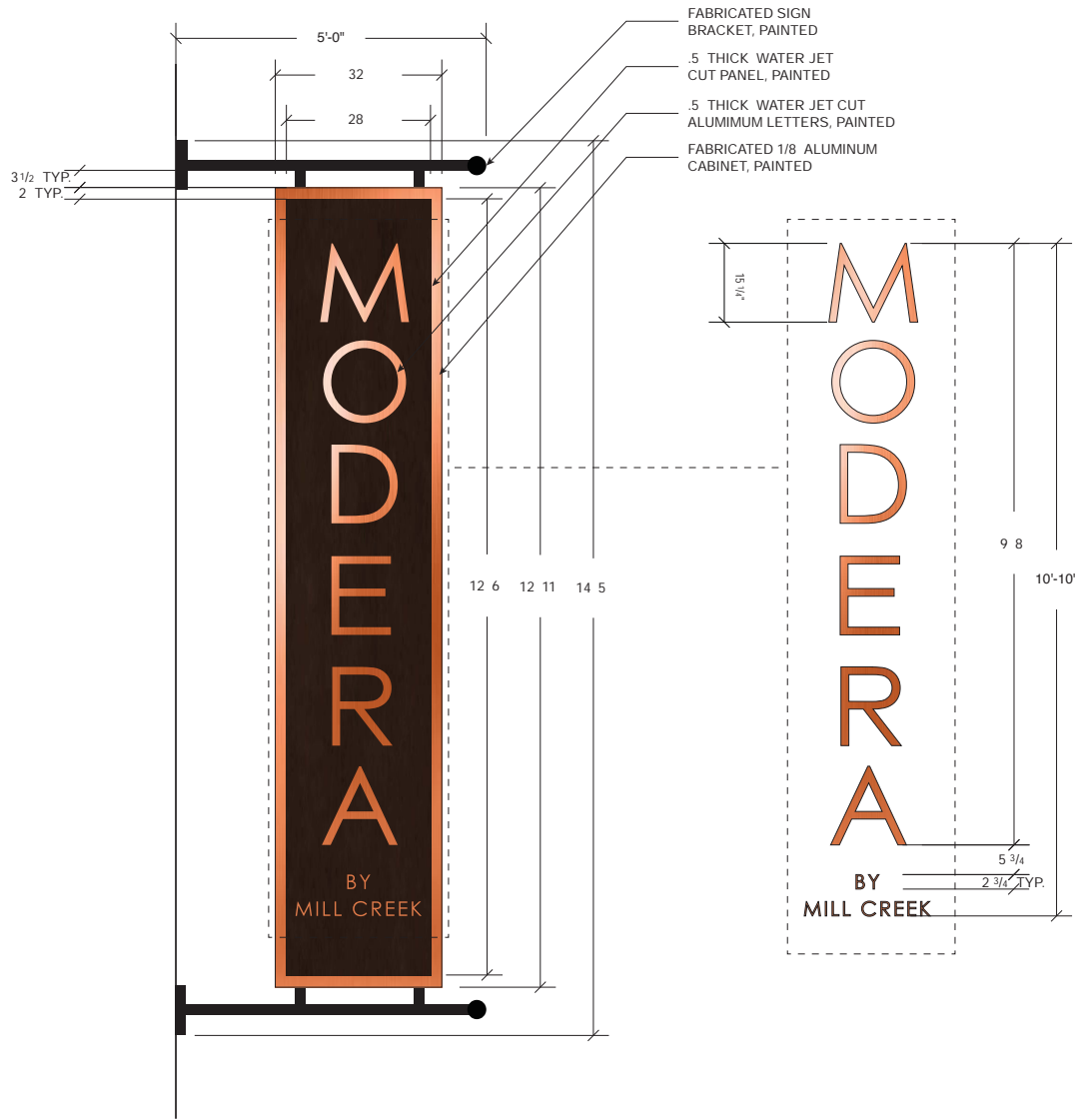

1 B IDS F E
 SCALE: 1/2" = 1'-0"

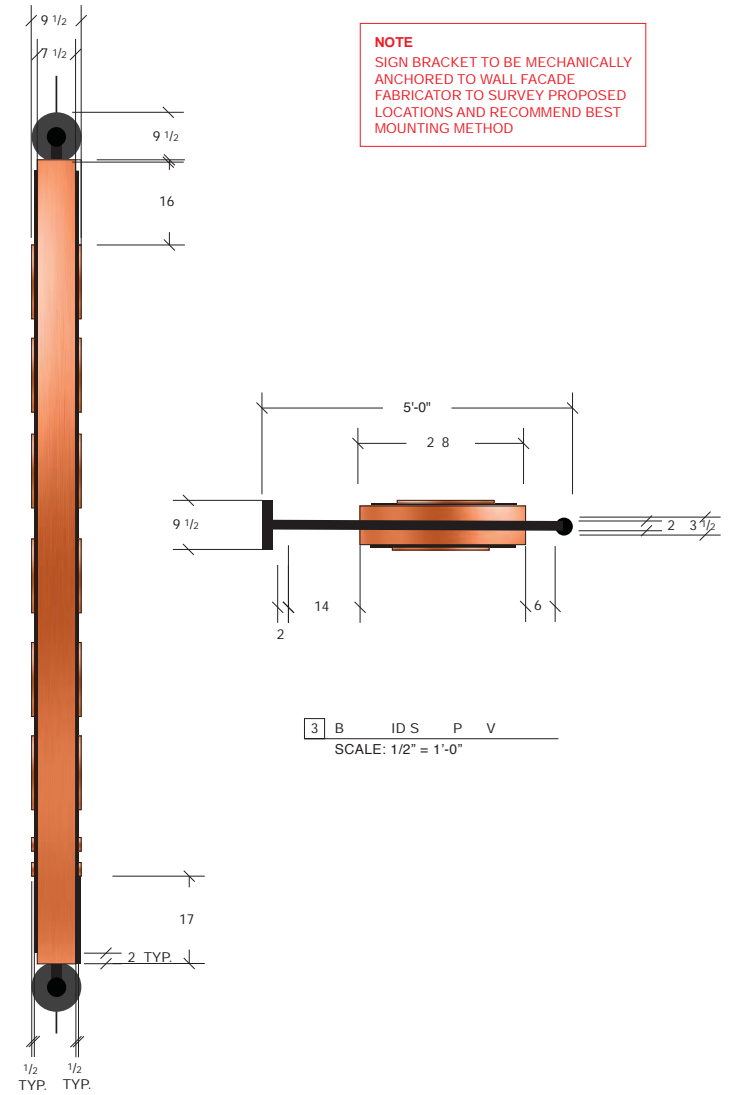

2 B IDS S E
 SCALE: 1/2" = 1'-0"

PROPOSED BUILDING ID SIGN AND LOCATIONS

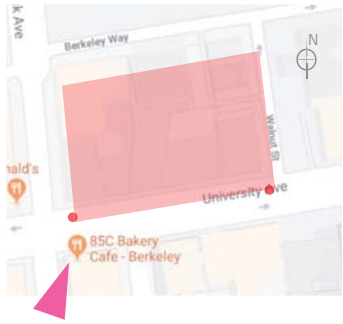

1 | B | ID S | C | R
SCALE NTS

BUILDING ID
Single Blade Sign

BUILDING ID
Single Blade Sign

PROPOSED BUILDING ID SIGN AND LOCATIONS



1 B ID S C R
SCALE NTS

BUILDING ID
Single Blade Sign

OPTION 2 - A PAIR OF BLADE SIGNS

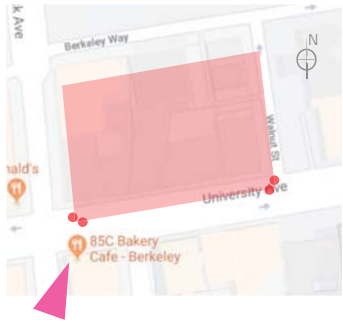

1 B ID S C R
SCALE NTS

BUILDING ID
A Pair of Blade Signs

BUILDING ID
A Pair of Blade Signs

OPTION 2 - A PAIR OF BLADE SIGNS

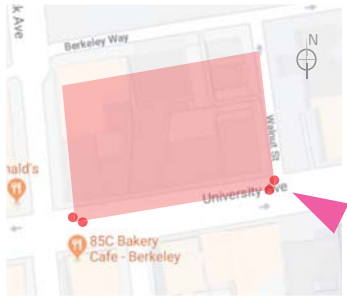

1 B ID S C R
SCALE NTS

BUILDING ID
A Pair of Blade Signs

OPTION 3 - FOUR SINGLE BLADE SIGNS

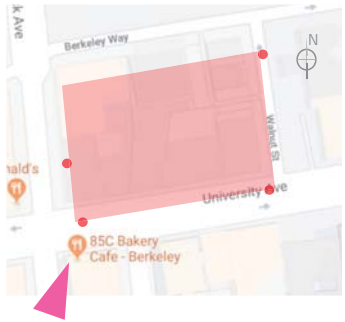

1 B ID S C R
SCALE NTS

BUILDING ID
Single Blade Sign

BUILDING ID
Single Blade Sign

BUILDING ID
Single Blade Sign

OPTION 3 - FOUR SINGLE BLADE SIGNS



1 B ID S C R
SCALE NTS

BUILDING ID
Single Blade Sign

BUILDING ID
Single Blade Sign

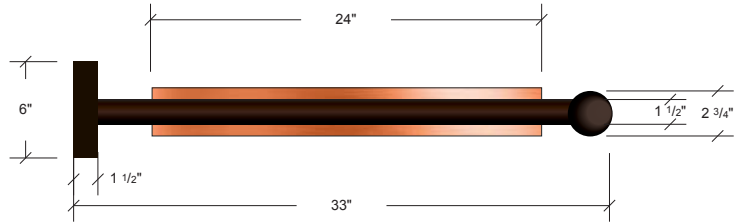

3 Blade Sign - Plan View
SCALE: 1 1/2" = 1'-0"

- FABRICATED SIGN BRACKET, PAINTED
- .5" THICK WATER-JET CUT PANEL, PAINTED
- .5" THICK WATER-JET CUT ALUMIMUM LOGO & LETTERS, PAINTED
- FABRICATED 1/8" ALUMINUM CABINET, PAINTED

NOTE:
SIGN BRACKET TO BE MECHANICALLY ANCHORED TO WALL FACADE - FABRICATOR TO SURVEY PROPOSED LOCATIONS AND RECOMMEND BEST MOUNTING METHOD



1 Blade Sign - Front Elevation
SCALE: 1 1/2" = 1'-0"

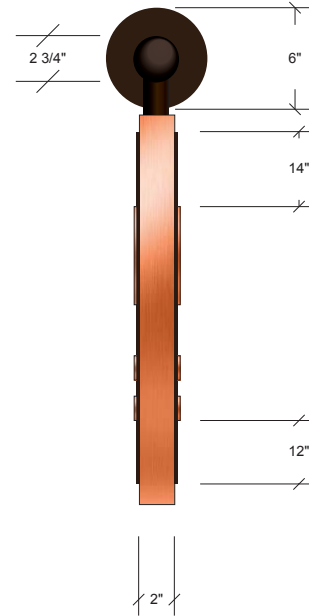

2 Blade Sign - Side Elevation
SCALE: 1 1/2" = 1'-0"

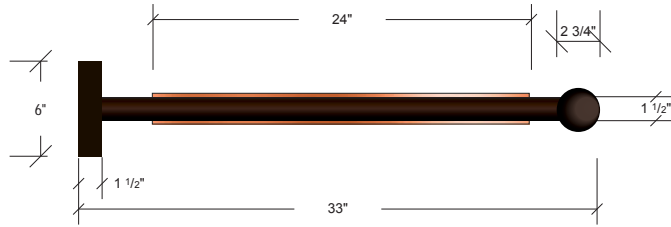

3 Tenant Blade Sign - Square - Plan View
SCALE: 1 1/2" = 1'-0"

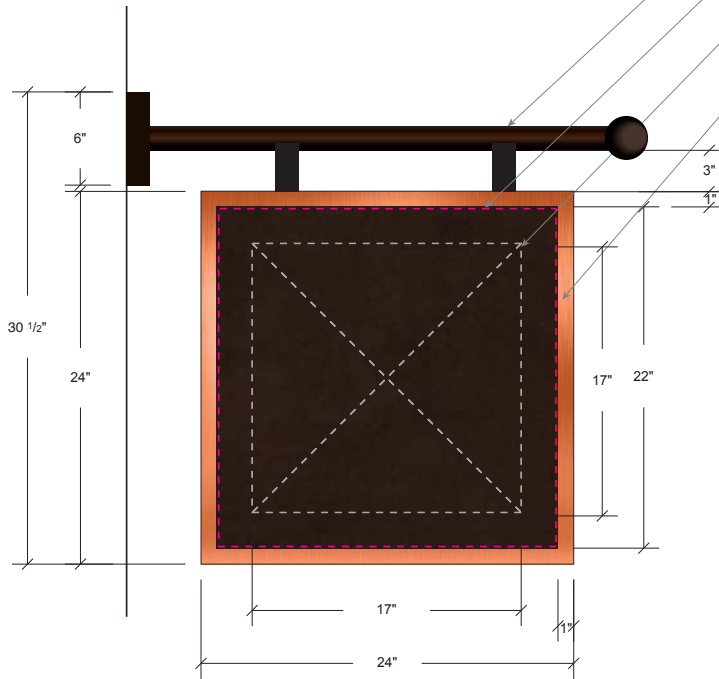

1 Tenant Blade Sign - Square - Front Elevation
SCALE: 1 1/2" = 1'-0"

- FABRICATED SIGN BRACKET, PAINTED
- .5" THICK REPLACABLE, DOUBLE SIDED PANEL FOR TENANT'S LOGO
- DESIGNATED AREA FOR TENANT LOGO/NAME
- FABRICATED 1/8" ALUMINUM CABINET, PAINTED

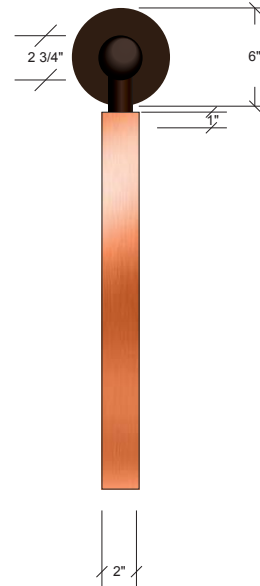

2 Tenant Blade Sign - Square - Side Elevation
SCALE: 1 1/2" = 1'-0"

NOTE:
SIGN BRACKET TO BE MECHANICALLY ANCHORED TO WALL FACADE – FABRICATOR TO SURVEY PROPOSED LOCATIONS AND RECOMMEND BEST MOUNTING METHOD

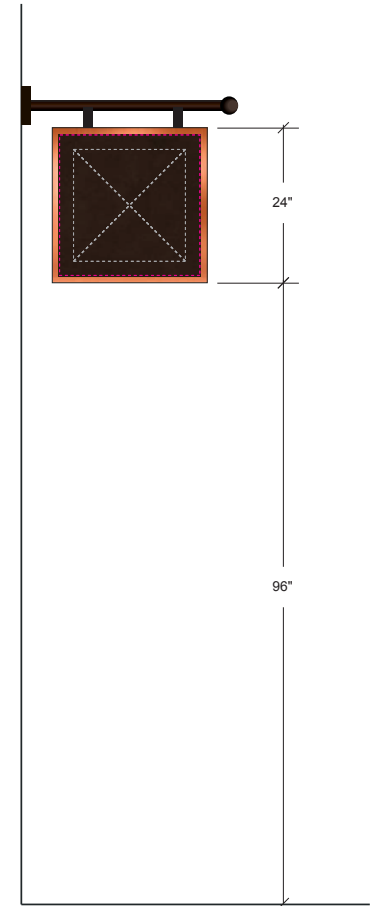

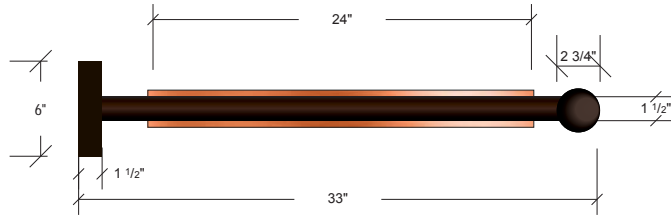

3 Tenant Blade Sign - Circle - Plan View
SCALE: 1 1/2" = 1'-0"

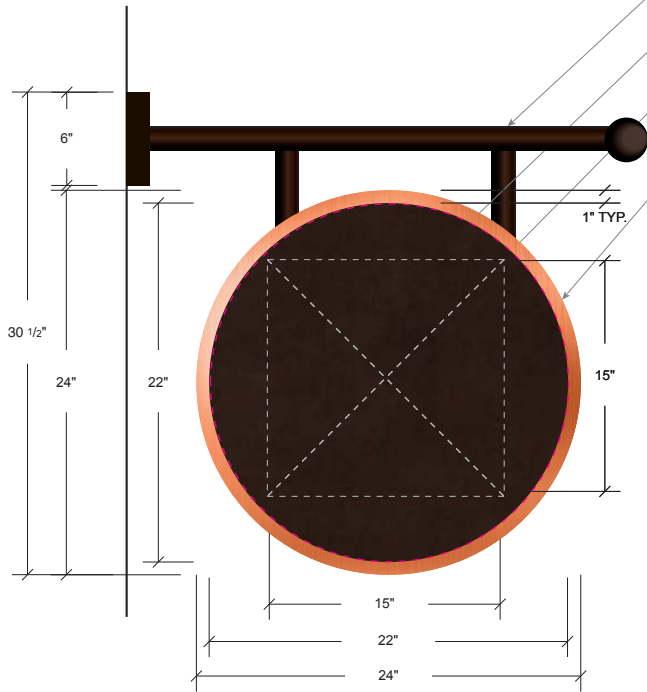

1 Tenant Blade Sign - Circle - Front Elevation
SCALE: 1 1/2" = 1'-0"

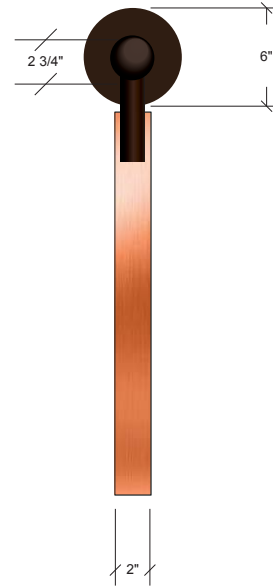

2 Tenant Blade Sign - Circle - Side Elevation
SCALE: 1 1/2" = 1'-0"

- FABRICATED SIGN BRACKET, PAINTED
- .5" THICK REPLACABLE, DOUBLE SIDED PANEL FOR TENANT'S LOGO
- DESIGNATED AREA FOR TENANT LOGO/NAME
- FABRICATED 1/8" ALUMINUM CABINET, PAINTED

NOTE:
SIGN BRACKET TO BE MECHANICALLY ANCHORED TO WALL FACADE – FABRICATOR TO SURVEY PROPOSED LOCATIONS AND RECOMMEND BEST MOUNTING METHOD

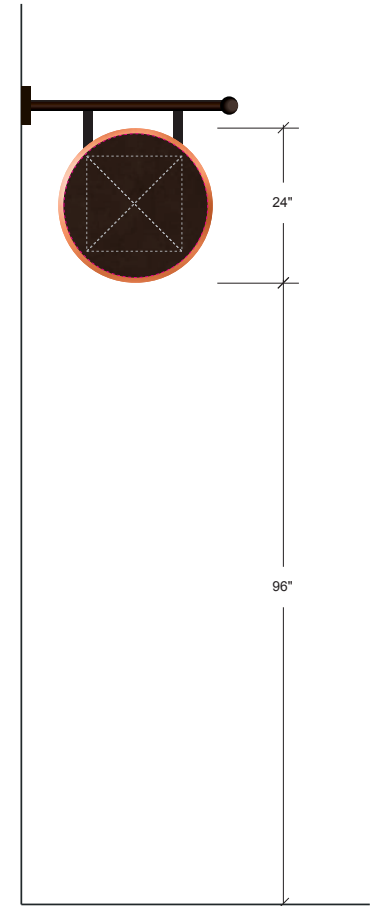

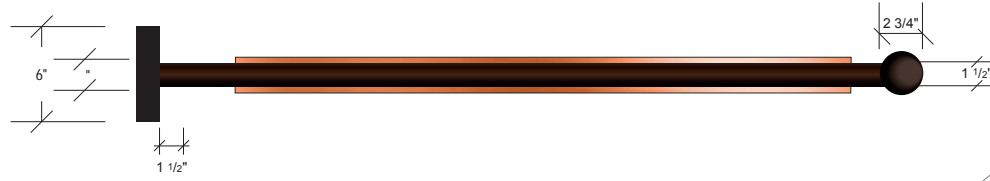

3 Tenant Blade Sign - Oval - Plan View
SCALE: 1 1/2" = 1'-0"

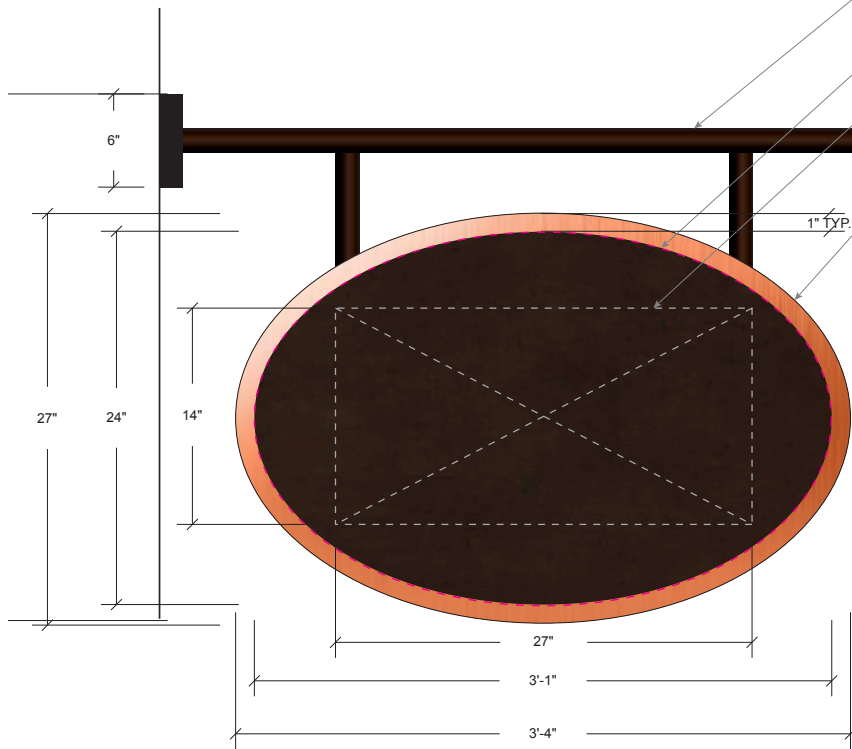

1 Tenant Blade Sign - Oval - Front Elevation
SCALE: 1 1/2" = 1'-0"

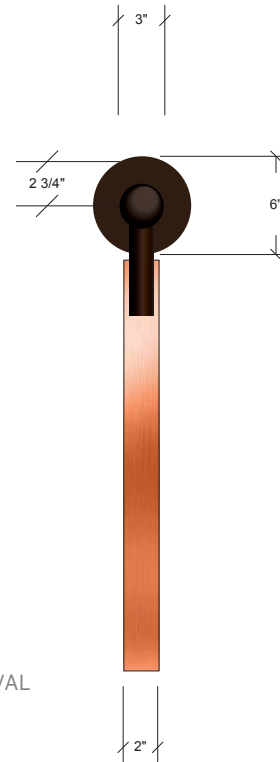

2 Tenant Blade Sign - Oval - Side Elevation
SCALE: 1 1/2" = 1'-0"

- FABRICATED SIGN BRACKET, PAINTED
- .5" THICK REPLACABLE, DOUBLE SIDED PANEL FOR TENANT'S LOGO
- DESIGNATED AREA FOR TENANT LOGO/NAME
- FABRICATED 1/8" ALUMINUM CABINET, PAINTED

NOTE:
SIGN BRACKET TO BE MECHANICALLY ANCHORED TO WALL FACADE – FABRICATOR TO SURVEY PROPOSED LOCATIONS AND RECOMMEND BEST MOUNTING METHOD

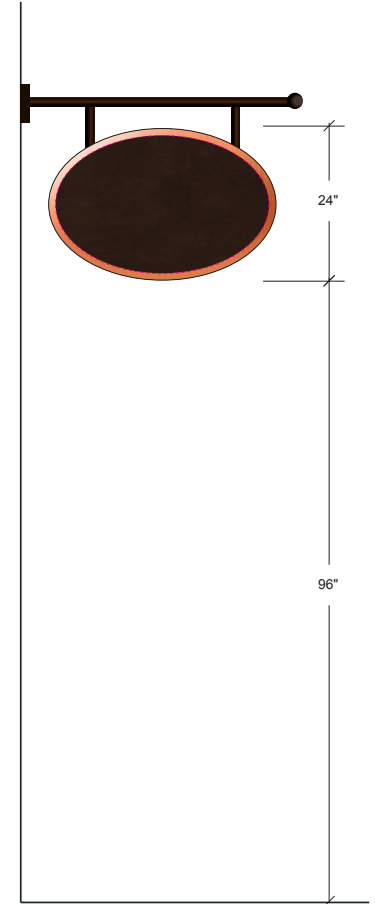

NOTE: This blade type - OVAL is only available as a third option for Building B, ACE, Tenant #6.



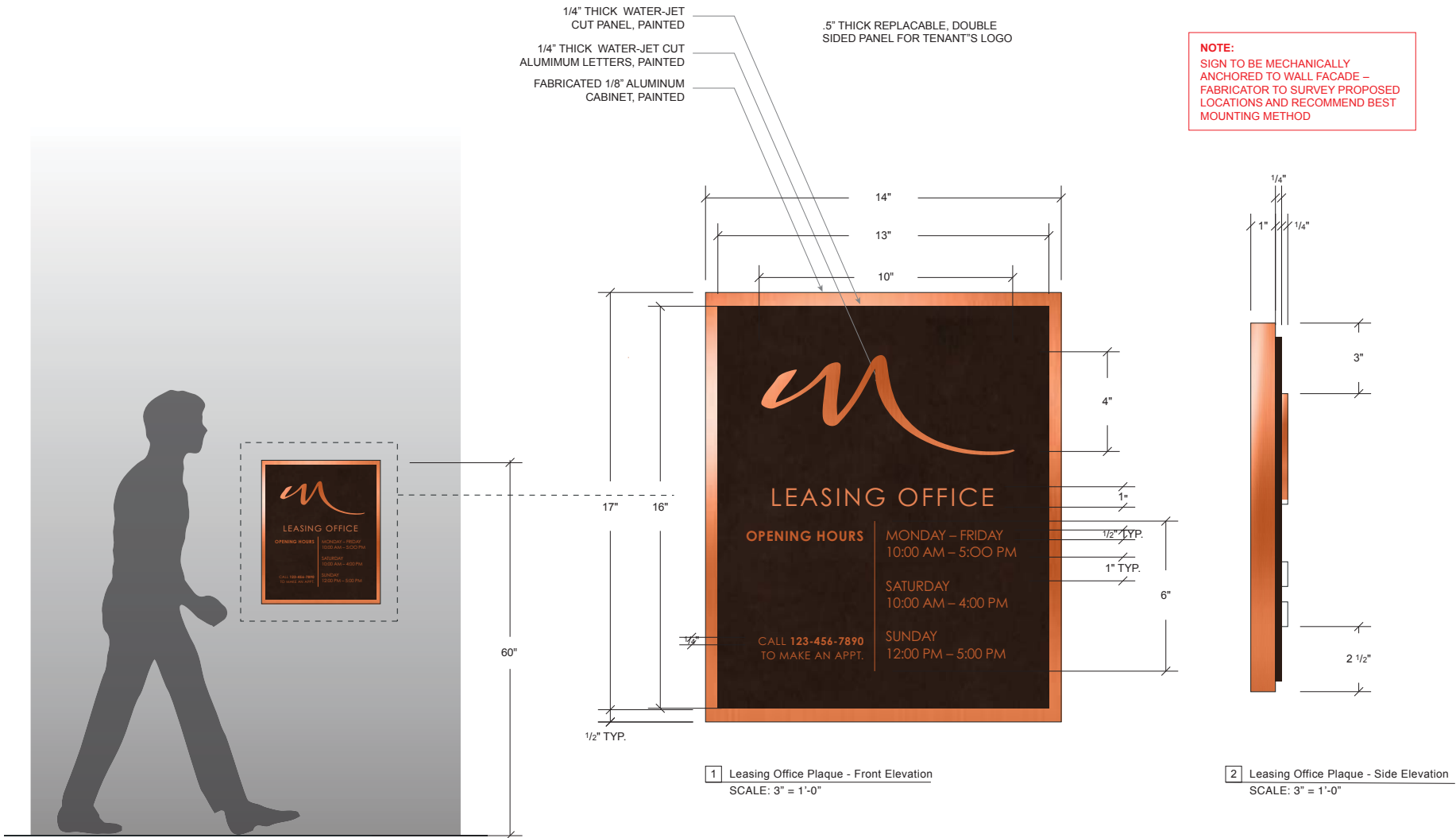

TYPE 1

NOTE
SIGN TO BE MECHANICALLY ANCHORED TO WALL FACADE
FABRICATOR TO SURVEY PROPOSED LOCATIONS AND RECOMMEND BEST MOUNTING METHOD

1/4 THICK WATER JET CUT PANEL, PAINTED
1/4 THICK WATER JET CUT ALUMINUM LETTERS, PAINTED
FABRICATED 1/8 ALUMINUM CABINET, PAINTED

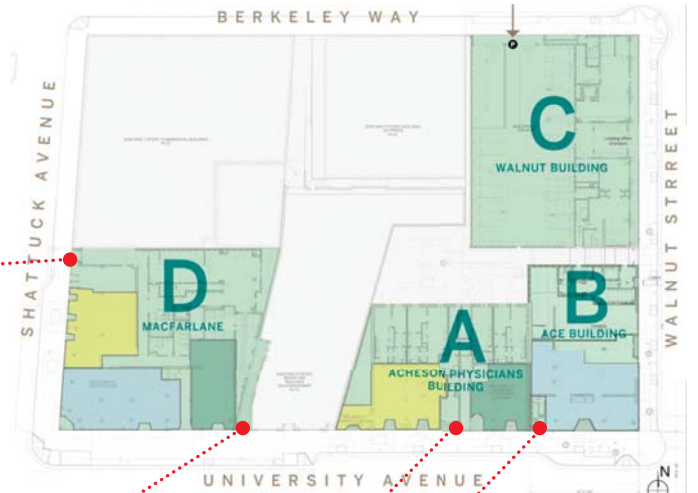
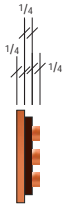

TYPE 2

NOTE
SIGN TO BE MECHANICALLY ANCHORED TO WALL FACADE
FABRICATOR TO SURVEY PROPOSED LOCATIONS AND RECOMMEND BEST MOUNTING METHOD

1/4 THICK WATER JET CUT PANEL, PAINTED
1/4 THICK WATER JET CUT ALUMINUM LETTERS, PAINTED
FABRICATED 1/8 ALUMINUM CABINET, PAINTED



TYPE 3

VINYL CUT OUT NUMBER
MATERIAL 3M
COLOR 921 BRON E
ANTIQUE METALLIC
FONTS: CENTURY GOTHIC, REGULAR
CENTURY GOTHIC, BOLD

NOTE
SIGN TO BE APPLIED TO GLASS

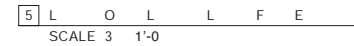

TYPE 1

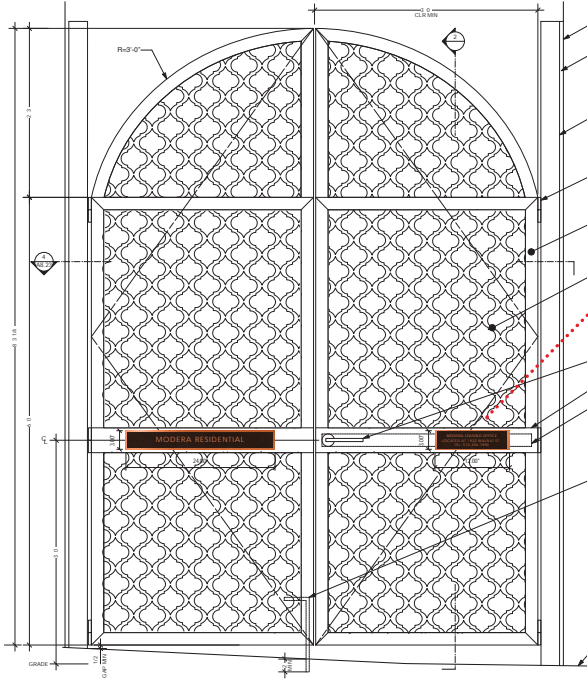

TYPE 2

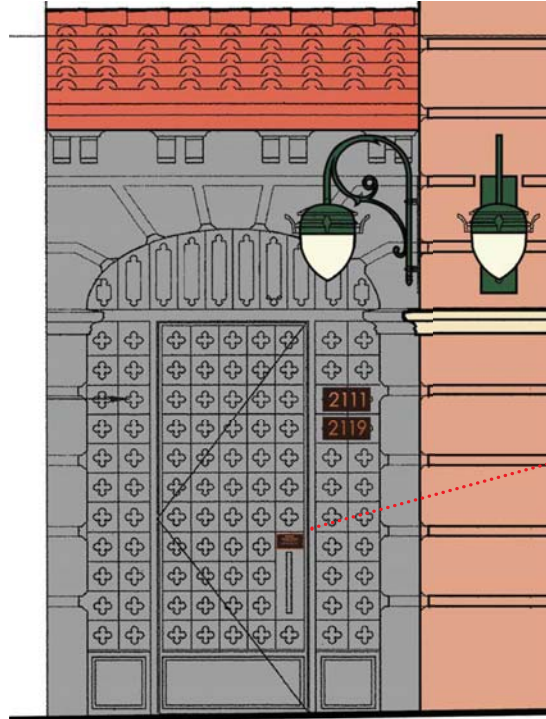

TYPE 3

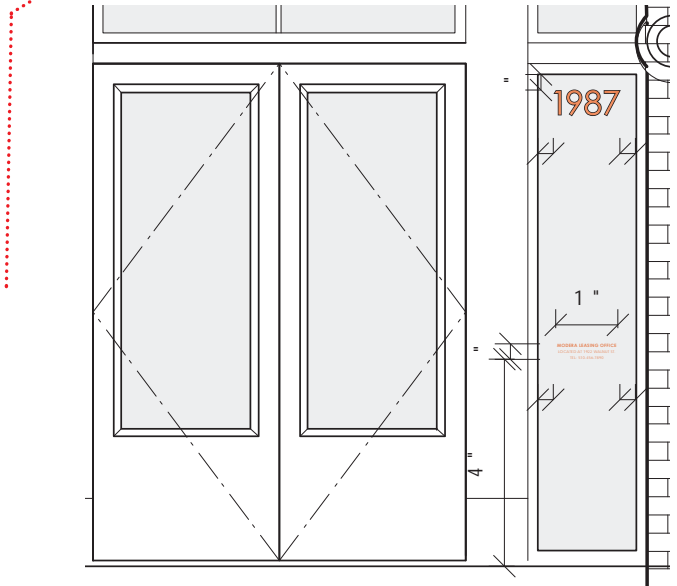

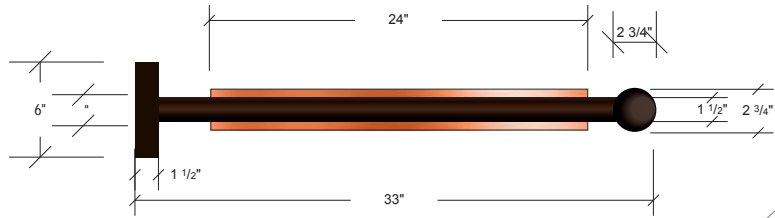

3 Parking ID Blade Sign - Plan View
SCALE: 1 1/2" = 1'-0"

- FABRICATED SIGN BRACKET, PAINTED
- .5" THICK WATER-JET CUT PANEL, PAINTED
- .5" THICK WATER-JET CUT ALUMINUM LETTERS, PAINTED
- FABRICATED 1/8" ALUMINUM CABINET, PAINTED

NOTE:
SIGN BRACKET TO BE MECHANICALLY ANCHORED TO WALL FACADE – FABRICATOR TO SURVEY PROPOSED LOCATIONS AND RECOMMEND BEST MOUNTING METHOD

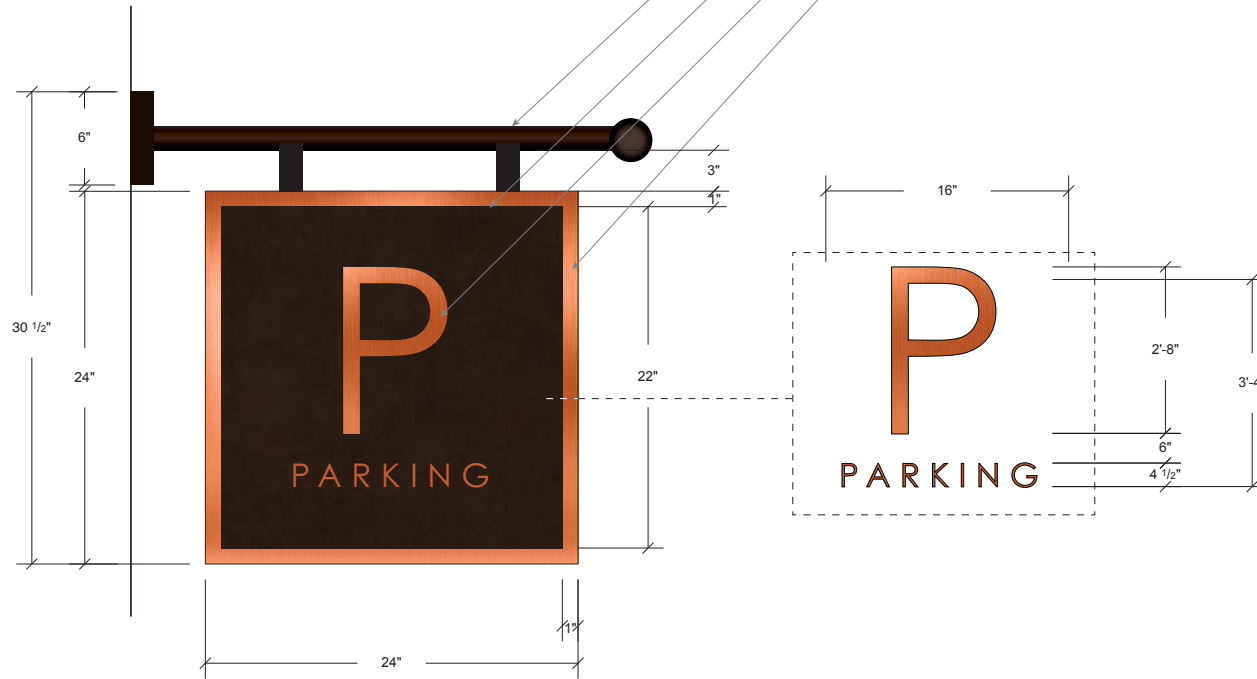

1 Parking ID Blade Sign - Front Elevation
SCALE: 1 1/2" = 1'-0"

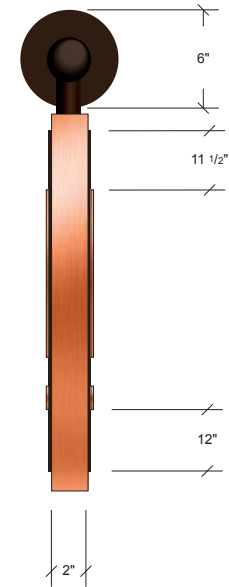

2 Parking ID Blade Sign - Side Elevation
SCALE: 1 1/2" = 1'-0"

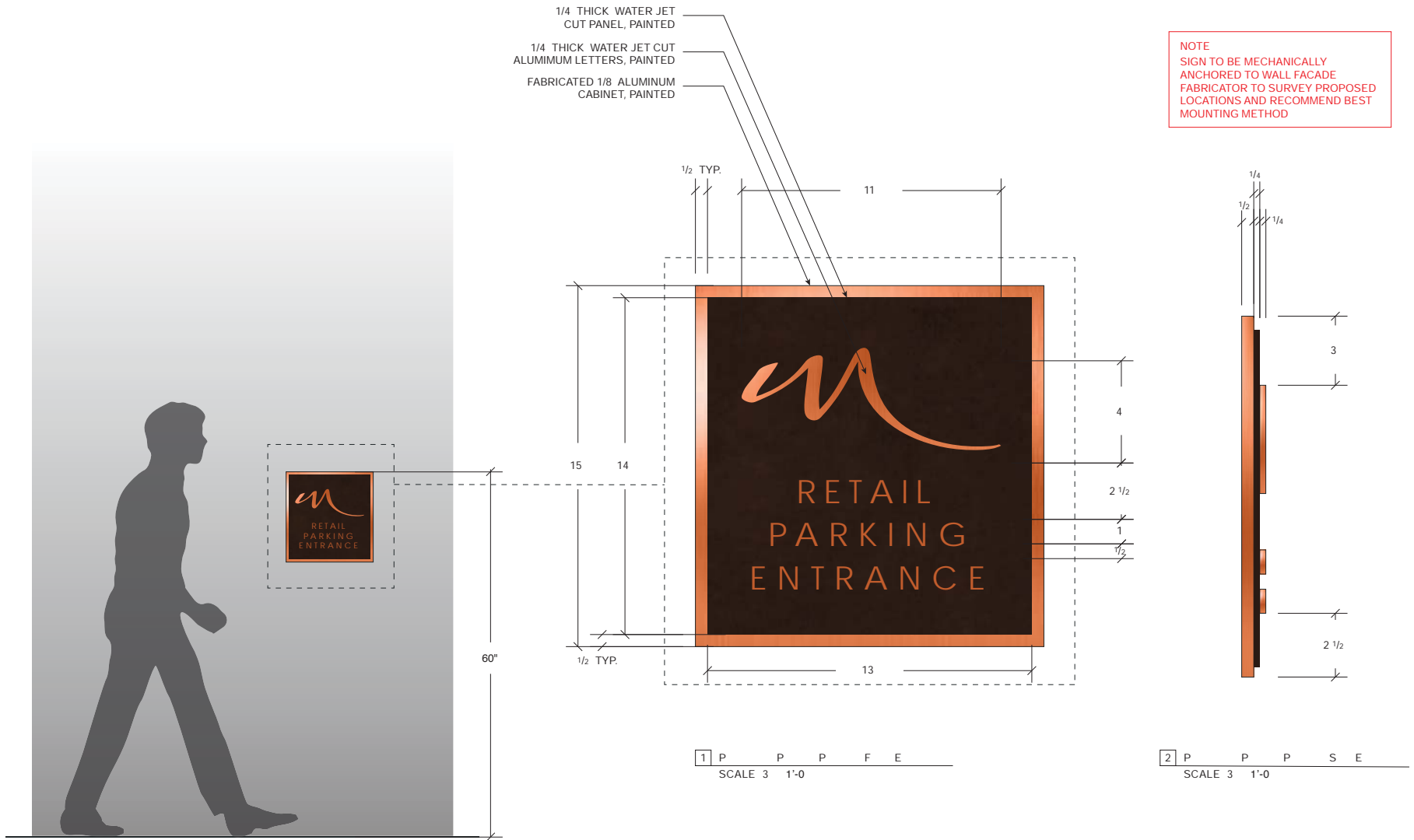

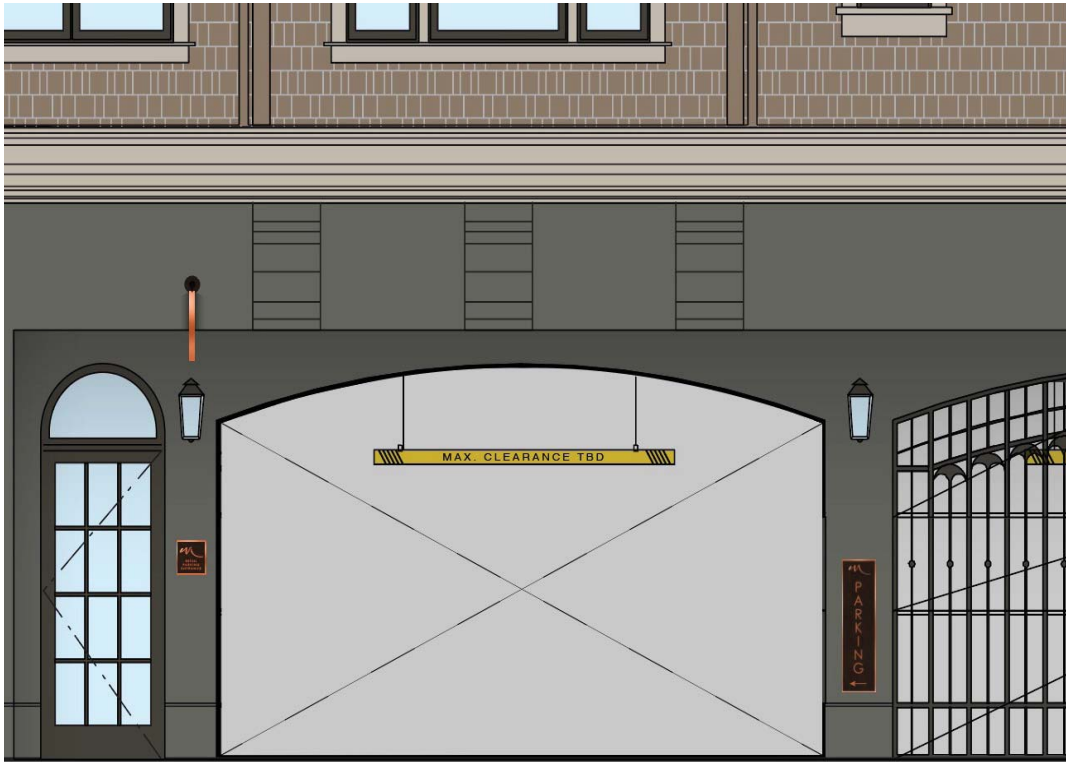

NOTE:
SIGN TO BE MECHANICALLY ANCHORED TO WALL FACADE - FABRICATOR TO SURVEY PROPOSED LOCATIONS AND RECOMMEND BEST MOUNTING METHOD

1 Vehicular Parking Plaque - Front Elevation
SCALE: 3" = 1'-0"

2 Vehicular Parking Plaque - Side Elevation
SCALE: 3" = 1'-0"

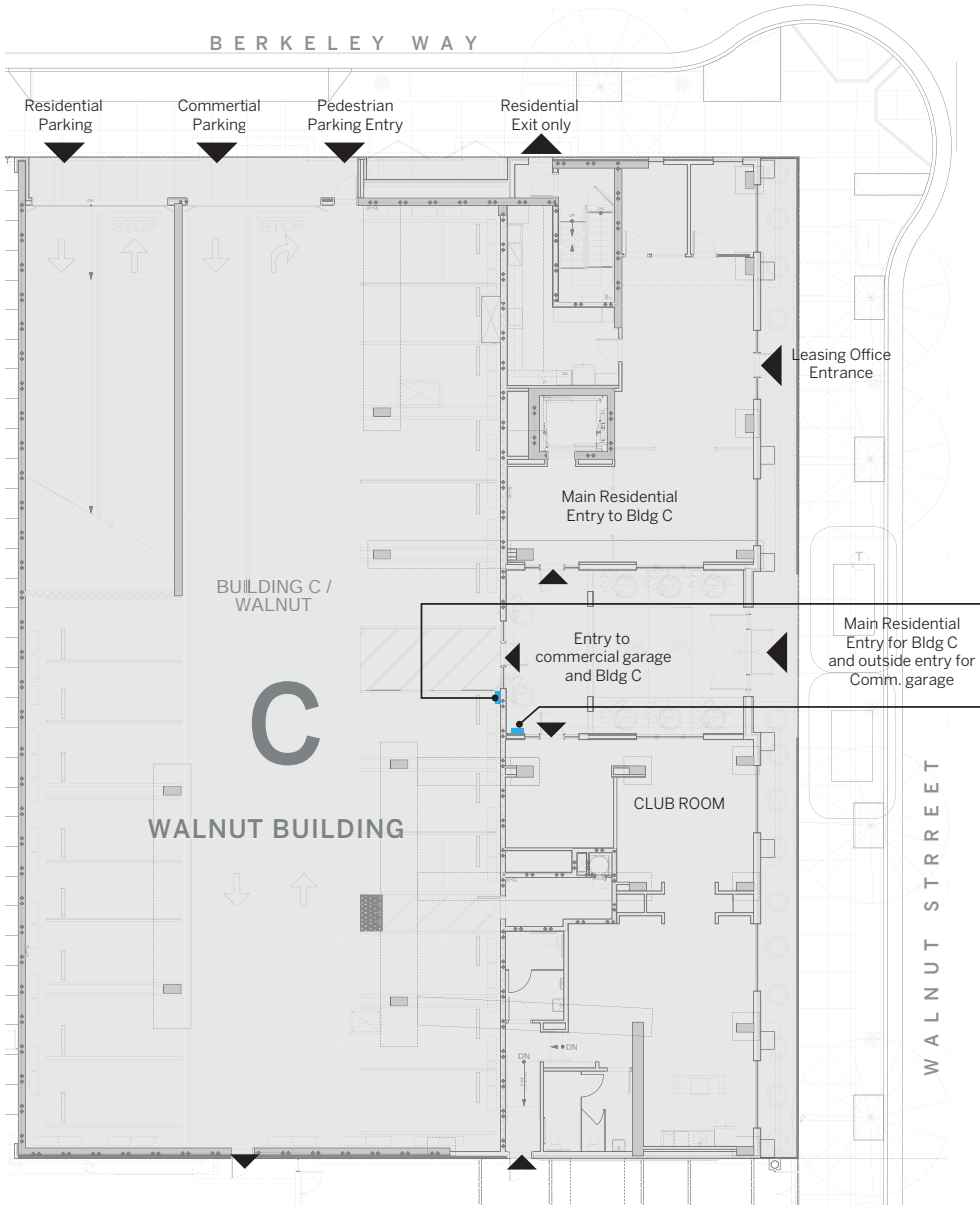

1 E M R F E
SCALE: 3" = 1'-0"



1B E M R F E / OPTIONAL WORDING
SCALE: 3" = 1'-0"



2 M C R P F E
SCALE: 3" = 1'-0"

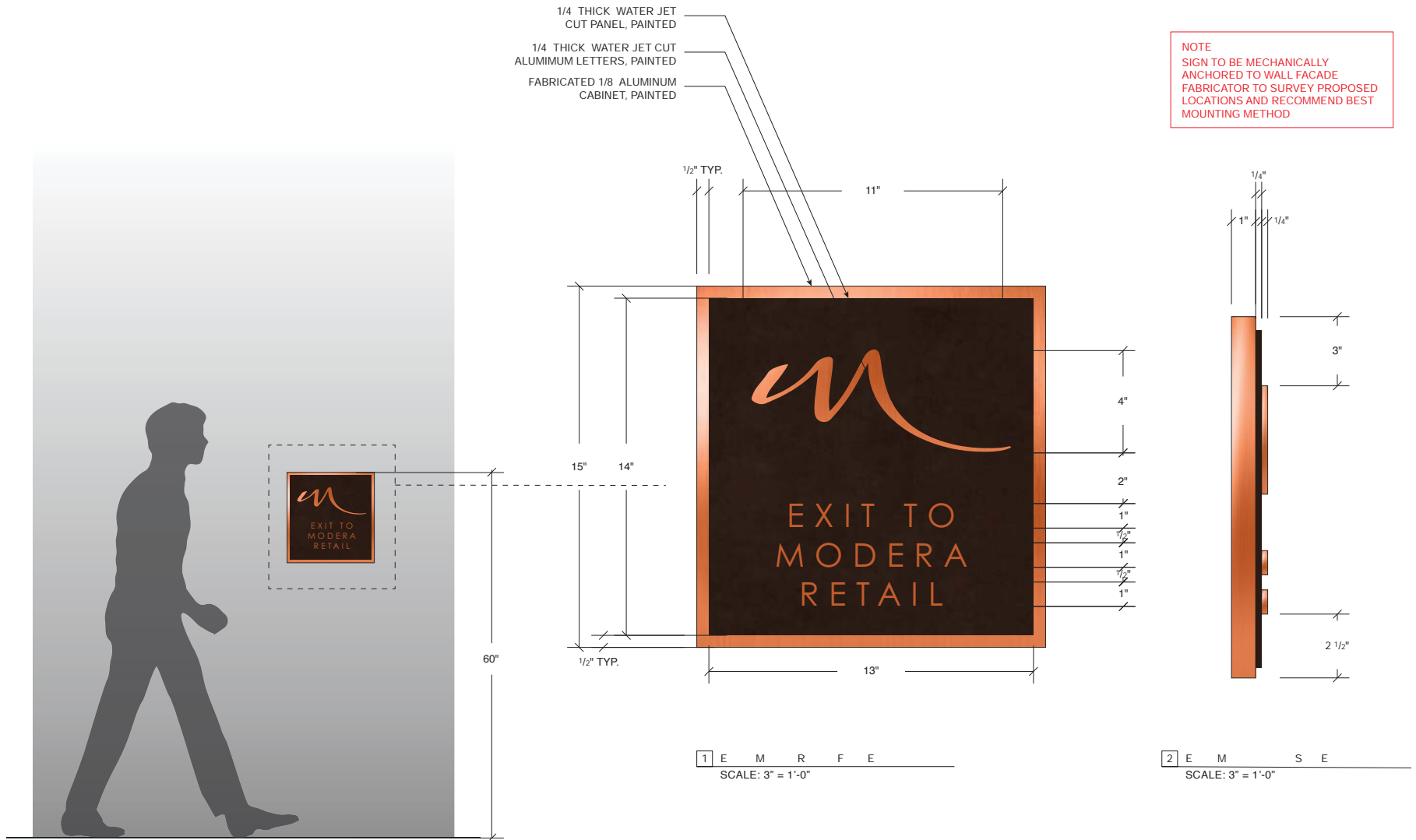

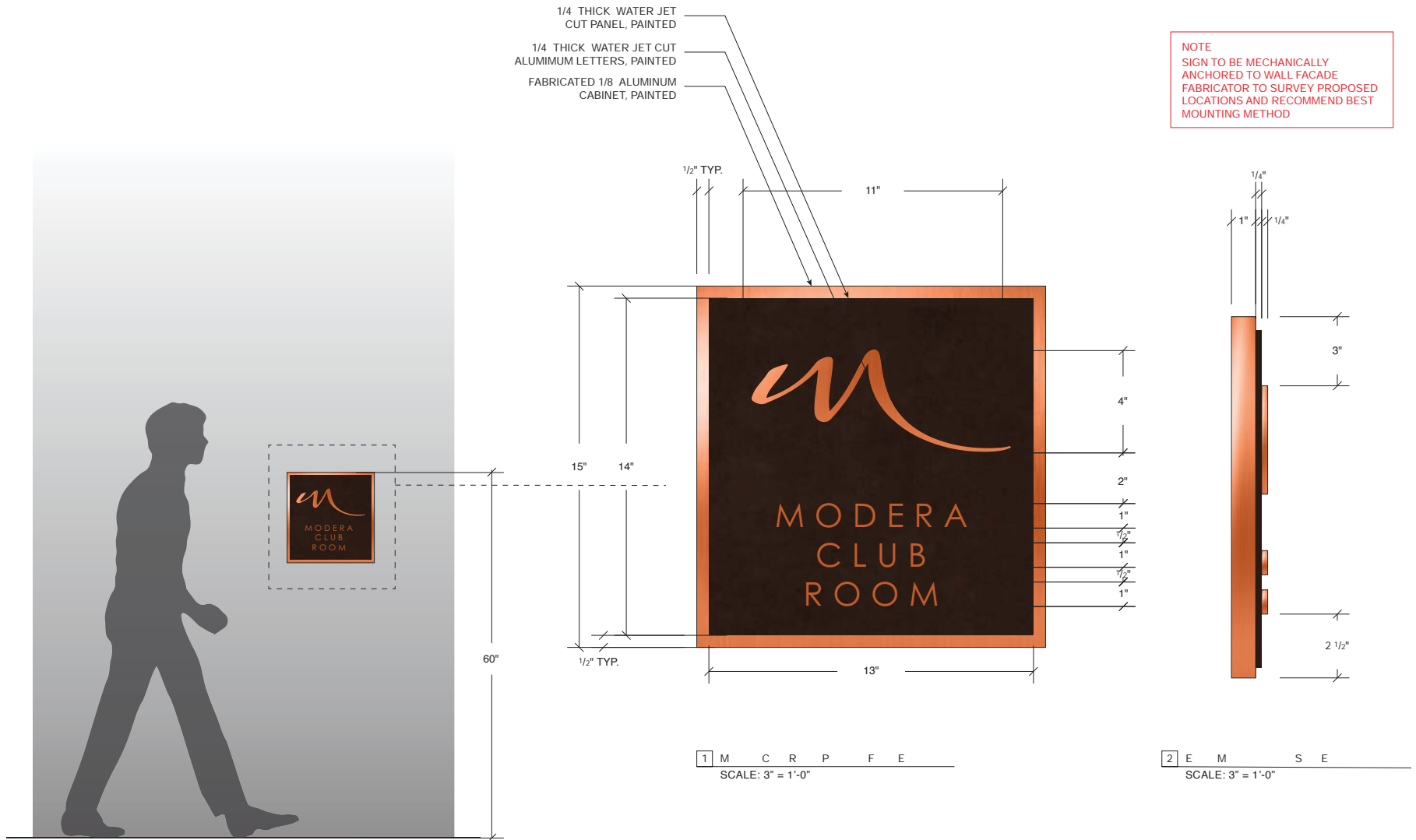

Window Sign Criteria

WINDOW SIGNS should not exceed 15% of the window area so that visibility into and out of the window is not obstructed. Use high-quality materials and techniques such as paint, gold-leaf, neon, and sandblasted or etched glass. Apply window signs directly to the interior face of the glazing, or hang signs inside the window. Cancel all mounting of hardware and equipment

Coordinate the design and alignment of signs on multiple use buildings in order to achieve a unified appearance rather than visual confusion.

WINDOW GRAPHIC
BRANDING OPPORTUNITIES

TENANT ENTRY SIGNAGE
SEE DETAIL

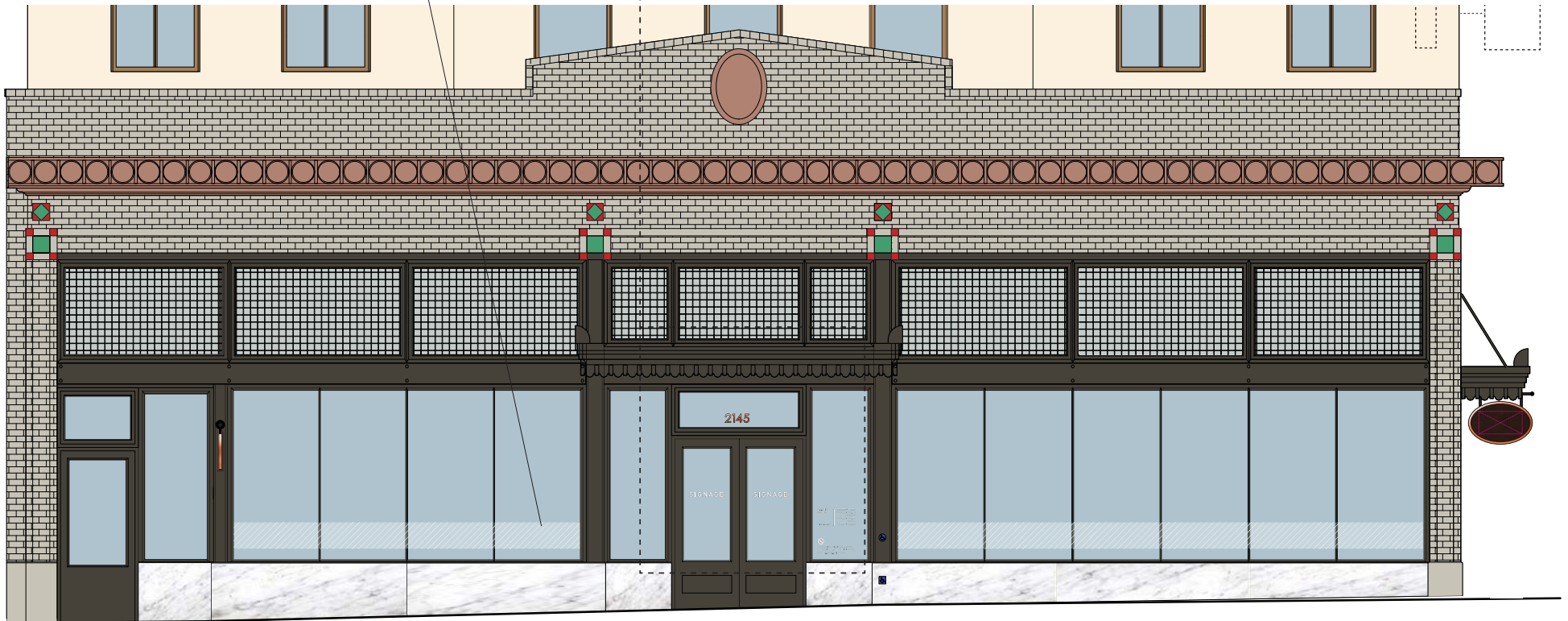

1 T T S F E / B O
SCALE NTS

Precedents:

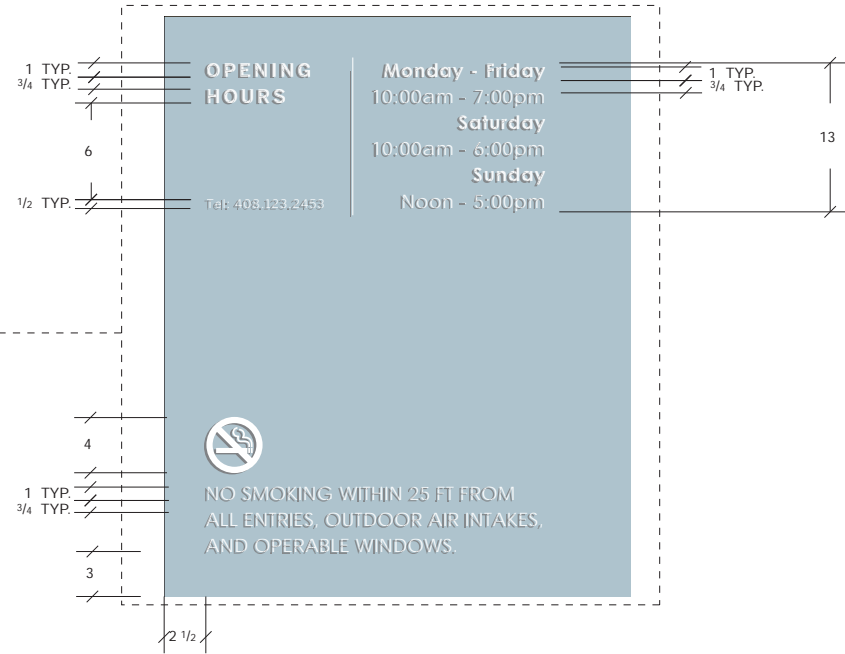
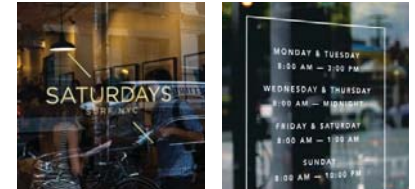

1 T T S F D D D
SCALE: 1/2" = 1'-0"



Precedents:

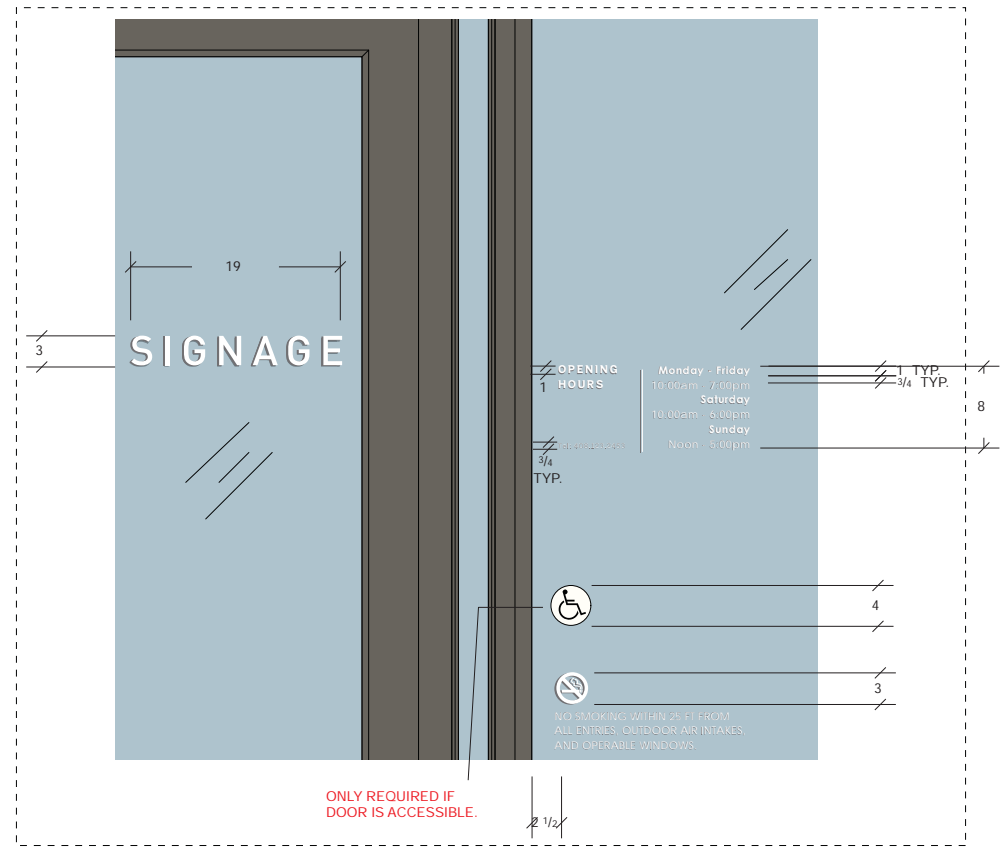

1 T T S F S D D
SCALE: 1/2" = 1'-0"



1 R A E D
SCALE: 1/2" = 1'-0"

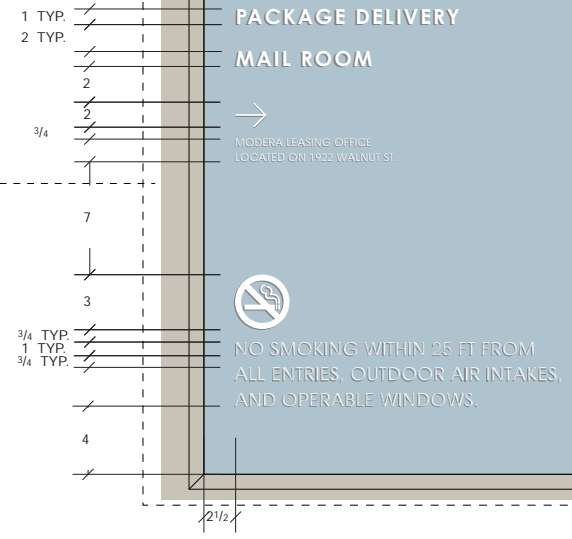

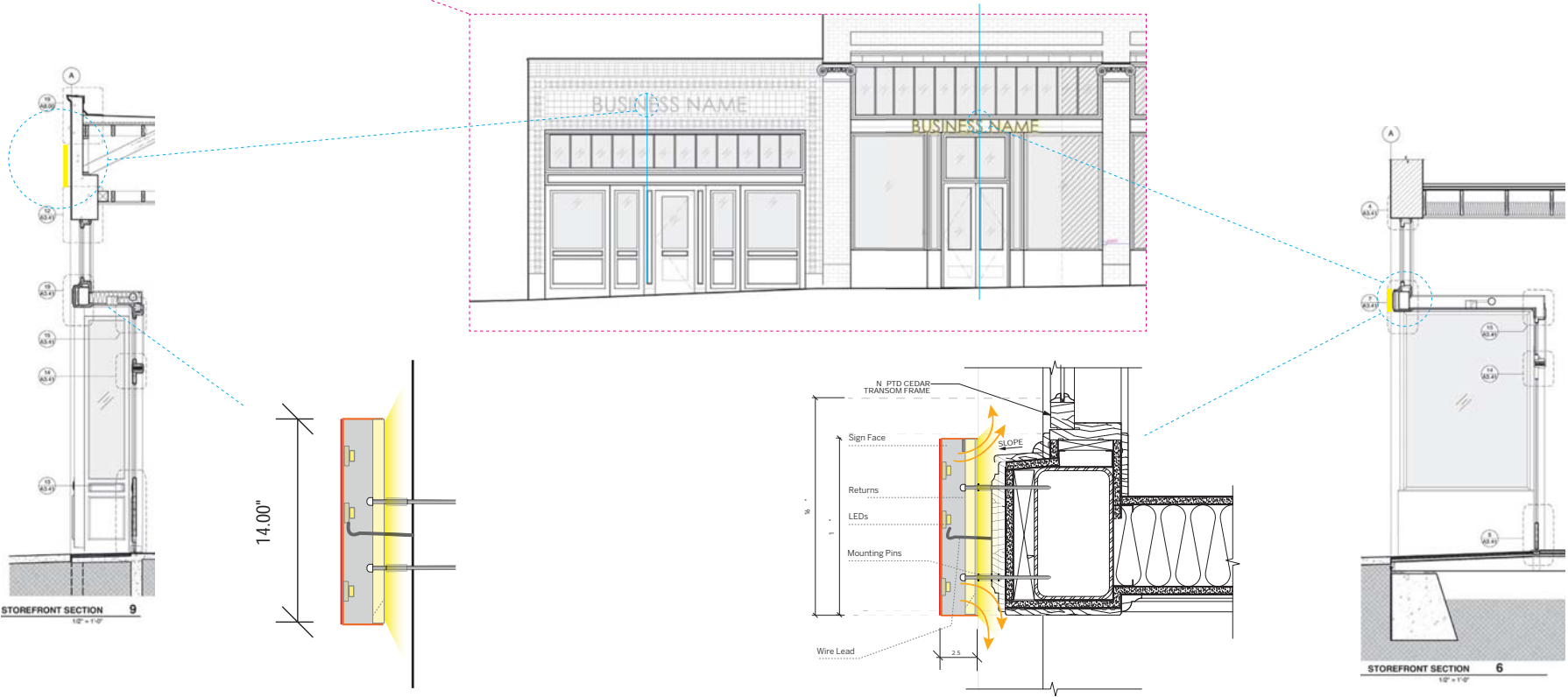



(OPTIONAL LOCATION) TENANT ID - DIMENSIONAL LETTERING

(COMMERCIAL) TENANT ID ON STOREFRONT TRANSOM.
 AVAILABLE THREE TYPES OF DIMENSIONAL LETTERING:
 1) HALO-LIT LETTERING
 2) PARTIAL-SIDE LIT DIMENSIONAL LETTERING
 3) DIMENSIONAL LETTERING

(OPTIONAL LOCATION) TENANT ID



Rendering of HALO-LIT LETTERING



(COMMERCIAL) TENANT ID ON STOREFRONT TRANSOM.
AVAILABLE THREE TYPES OF DIMENSIONAL LETTERING:
1) HALO-LIT LETTERING
2) PARTIAL-SIDE LIT DIMENSIONAL LETTERING
3) DIMENSIONAL LETTERING

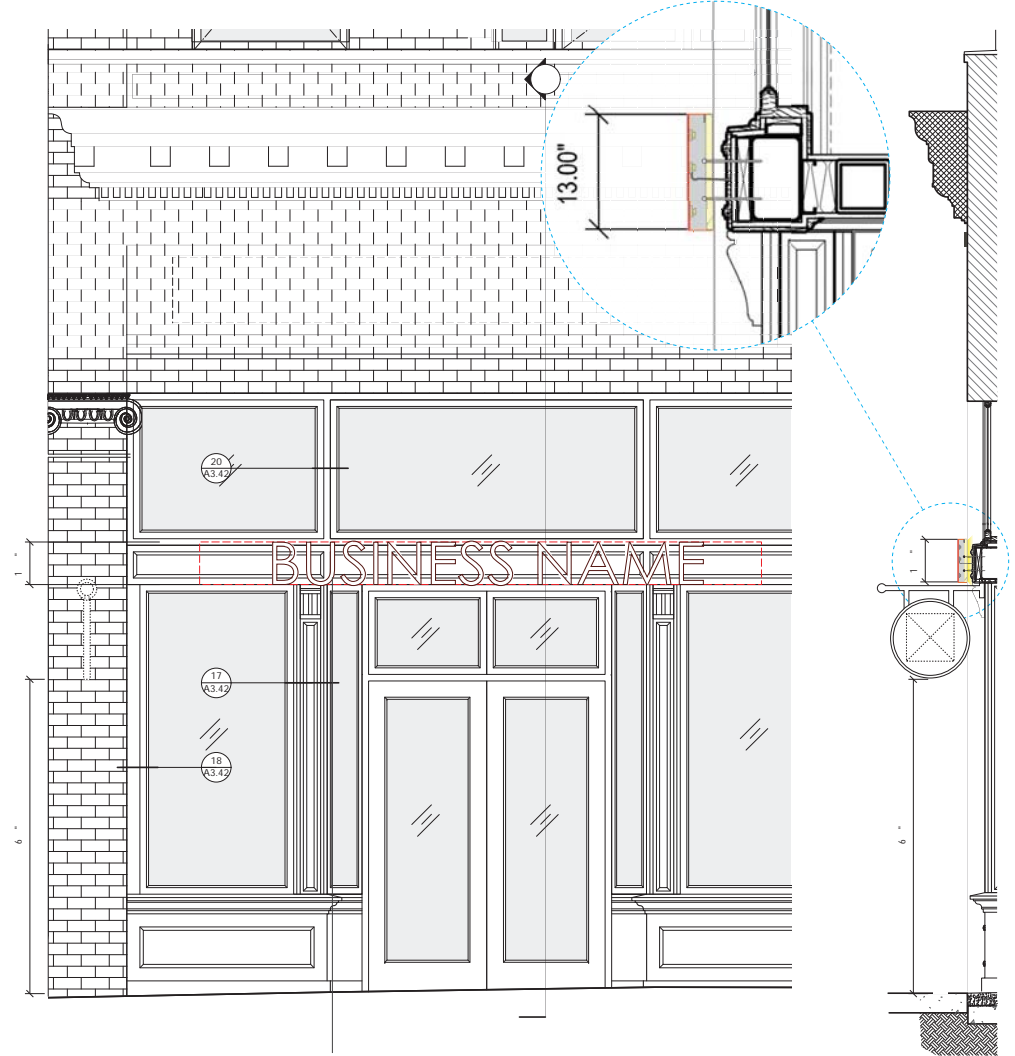

(COMMERCIAL) TENANT ID ON STOREFRONT TRANSM.
 AVAILABLE THREE TYPES OF DIMENSIONAL LETTERING:
 1) HALO-LIT LETTERING
 2) PARTIAL-SIDE LIT DIMENSIONAL LETTERING
 3) DIMENSIONAL LETTERING

STOREFRONT SIGNAGE DIMENSIONAL LETTERING

TYPE 1 HALO-LIT LETTERING

Precedents:

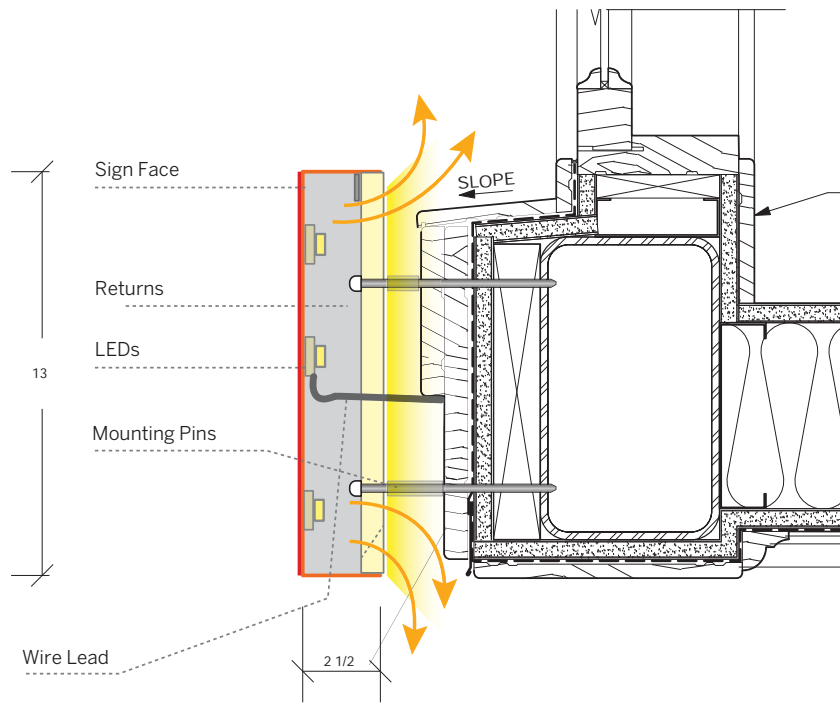

STOREFRONT SIGNAGE

TYPE 2 PARTIAL-SIDE LIT DIMENSIONAL LETTERING

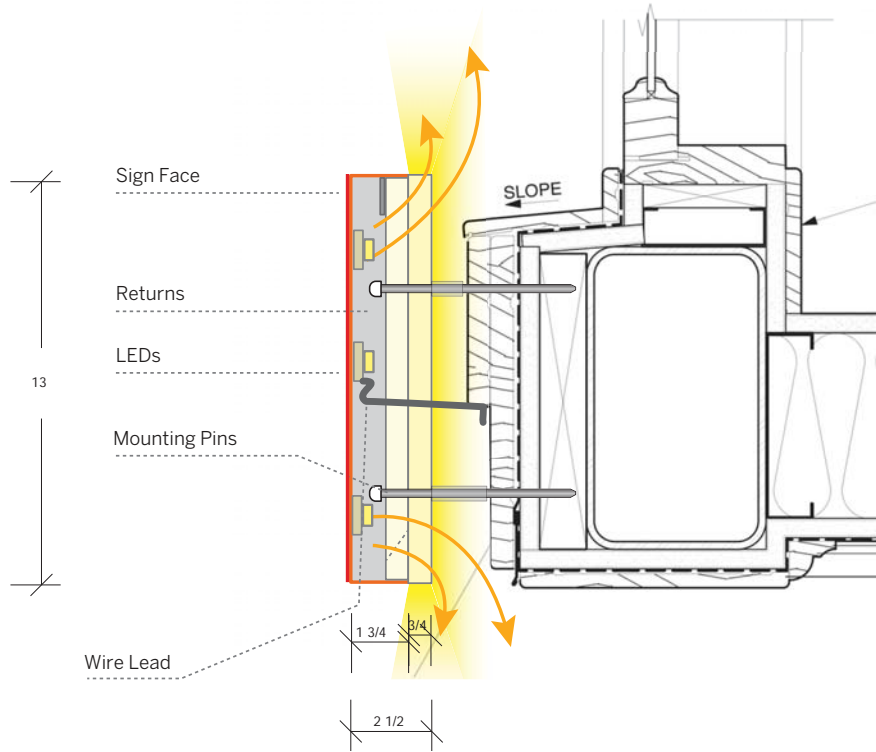

Precedents:

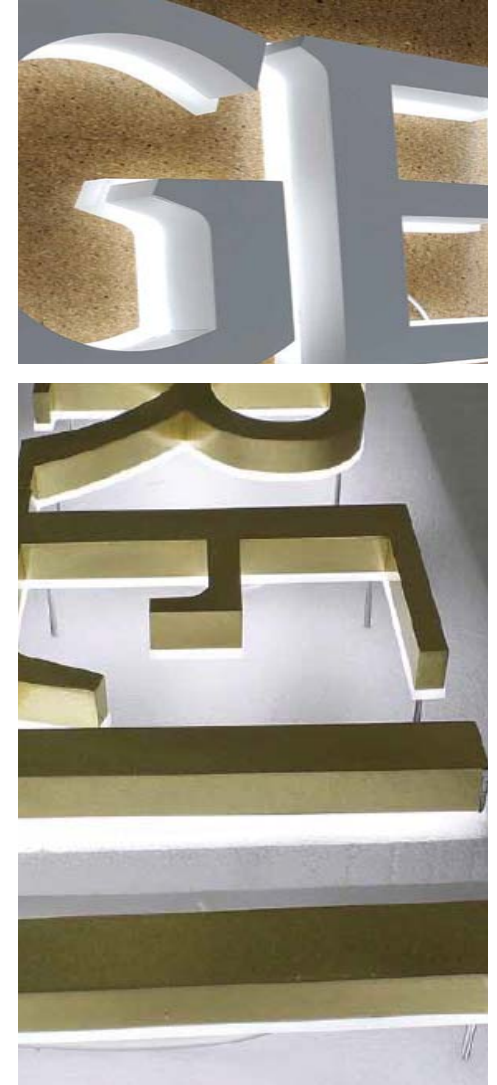

STOREFRONT SIGNAGE

TYPE 3 DIMENSIONAL LETTERING

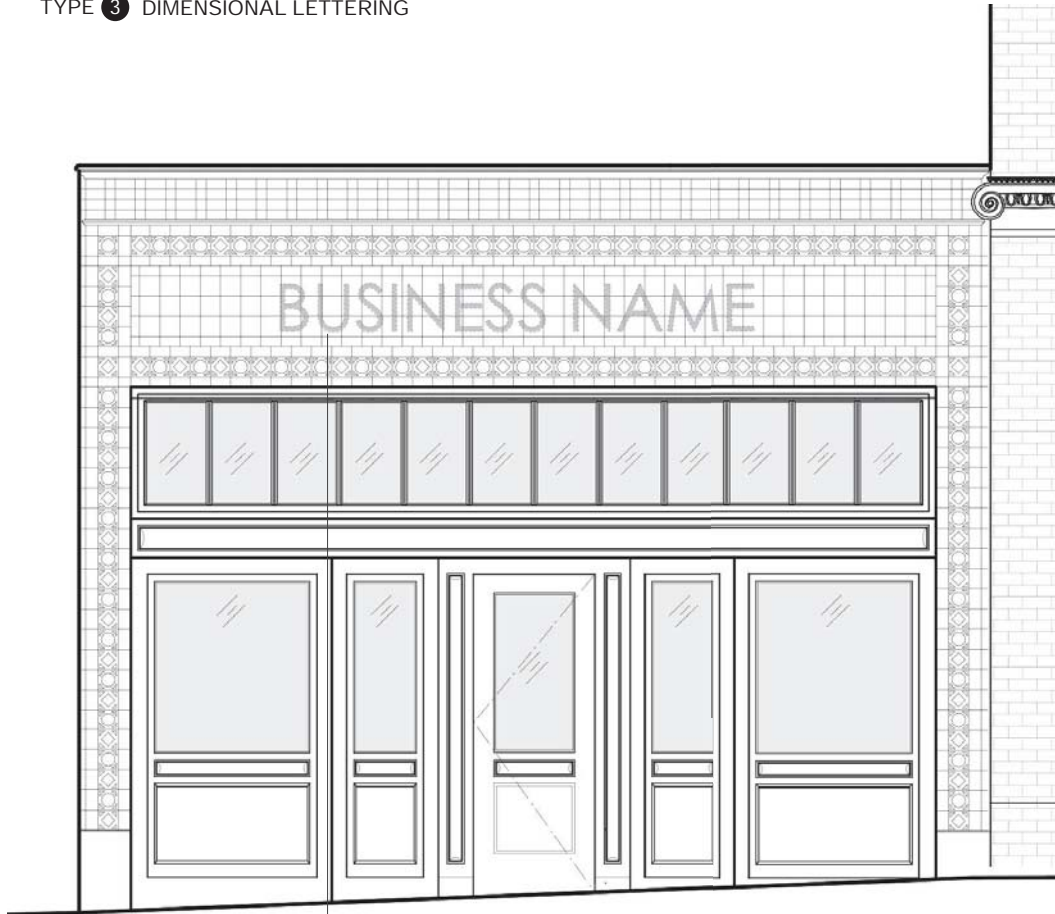

TENNAT ID (OPTIONAL LOCATION)

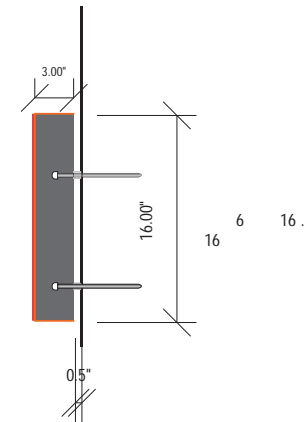

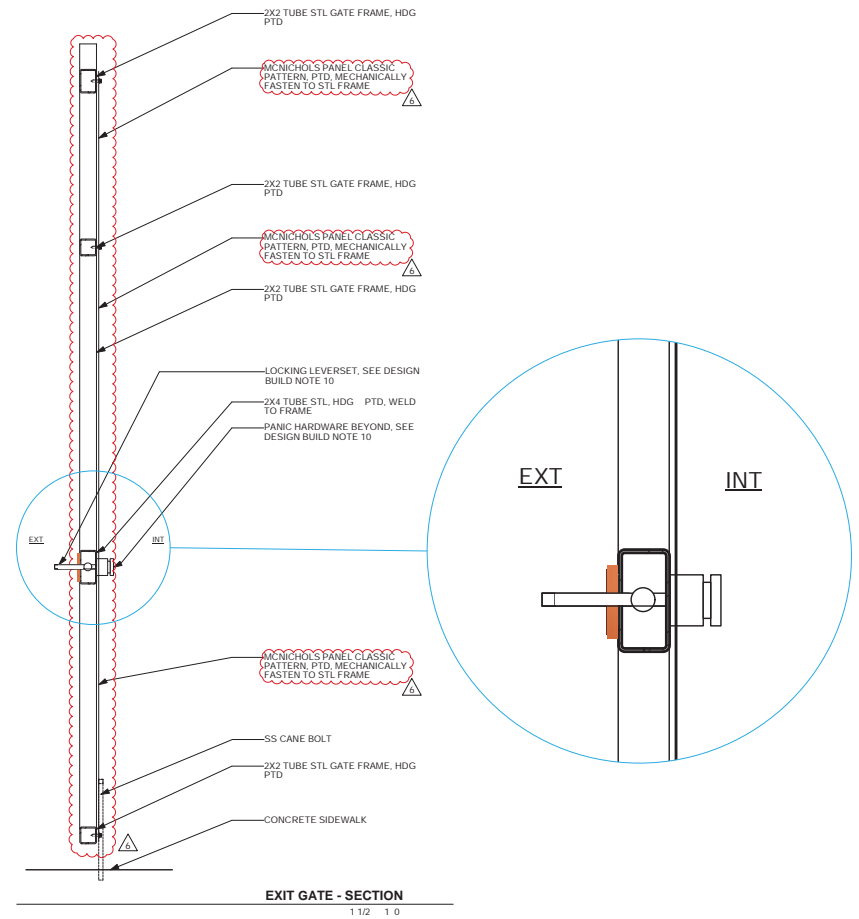
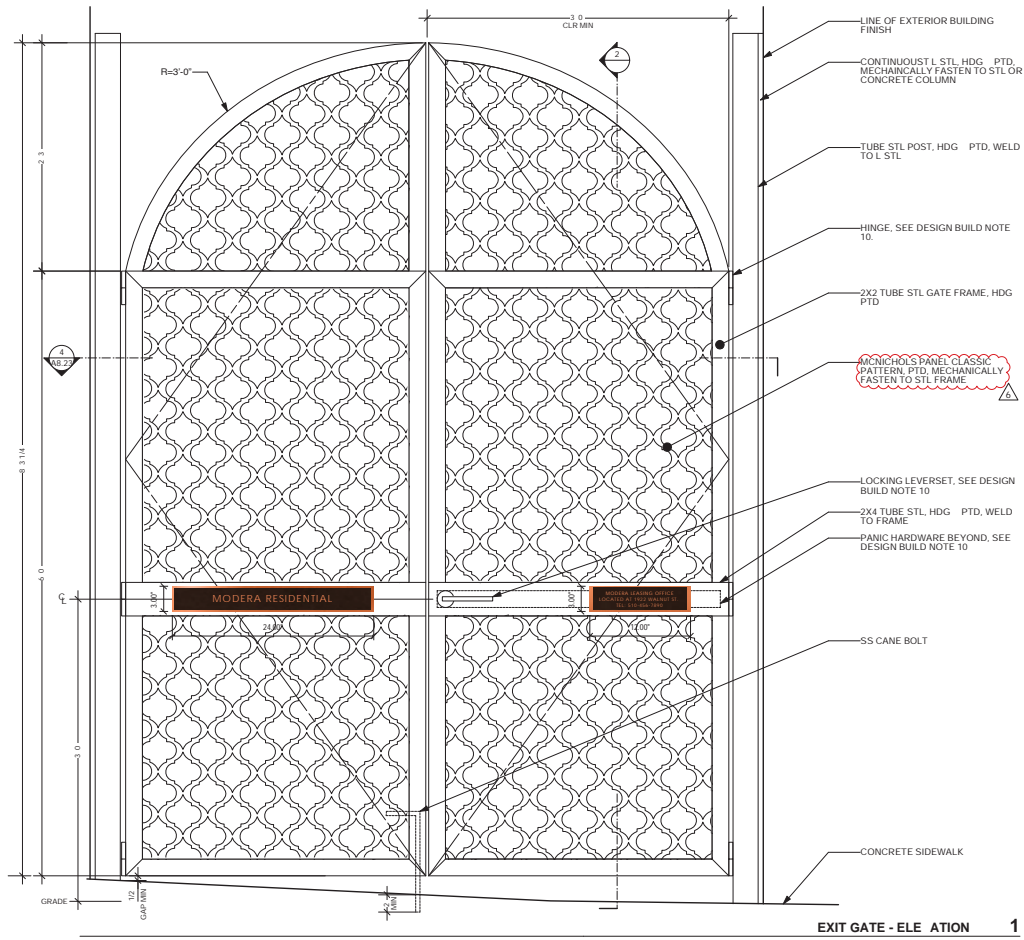

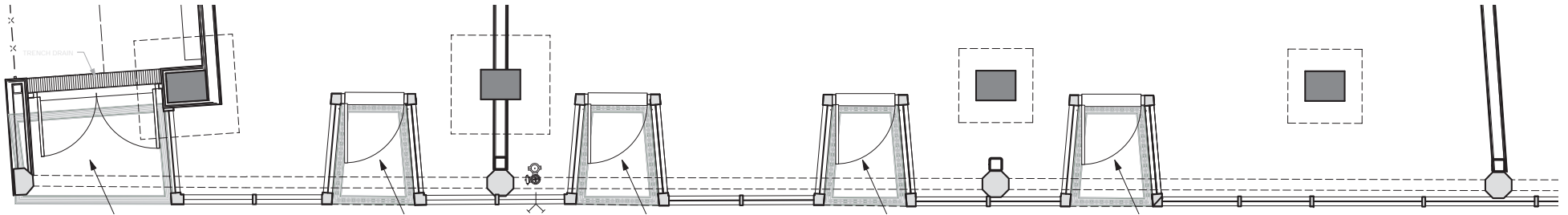
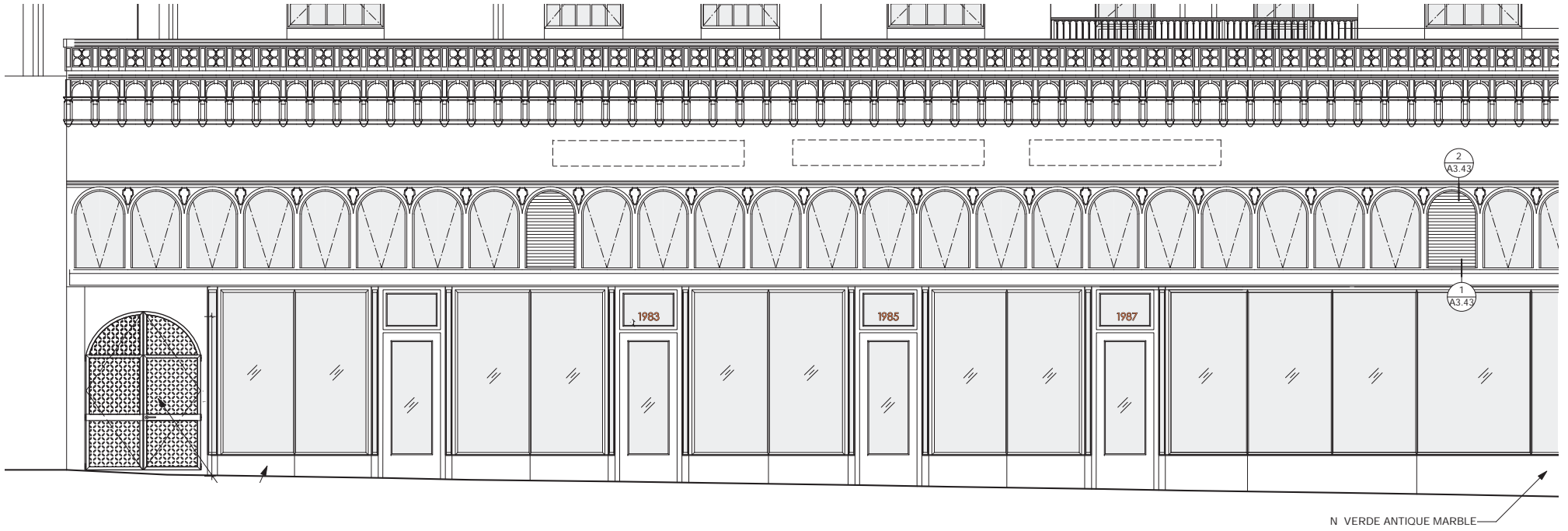

STREET NUMBERING

Shattuck 1979 1981 1983 1985 1987

University 2101 2103 2105 2107 2109
2111 2113 2119 2121 2123
2125 2127 2129 2131 2133 2135
2137 2139 2141 2143 2145

Walnut 1922 1924 1930

STREET NUMBERING

TYPE 1 APPLICATION ON GLASS



1 Vinyl Street Number F E
SCALE 1 1



2 Vinyl Street Number F E
SCALE 3 1'-0

TYPE 2 APPLICATION ON WALL OR ENTRANCE GATE

See next page for specific locations

P
2011 University Avenue
2019 University Avenue



NOTE
SIGN TO BE MECHANICALLY
ANCHORED TO GATE FACADE
FABRICATOR TO SURVEY PROPOSED
LOCATIONS AND RECOMMEND BEST
MOUNTING METHOD

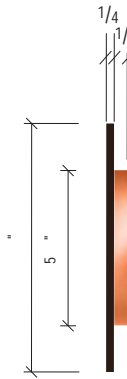

3 S N P S E
SCALE 3 1'-0



4 S N P F E
SCALE 3 1'-0

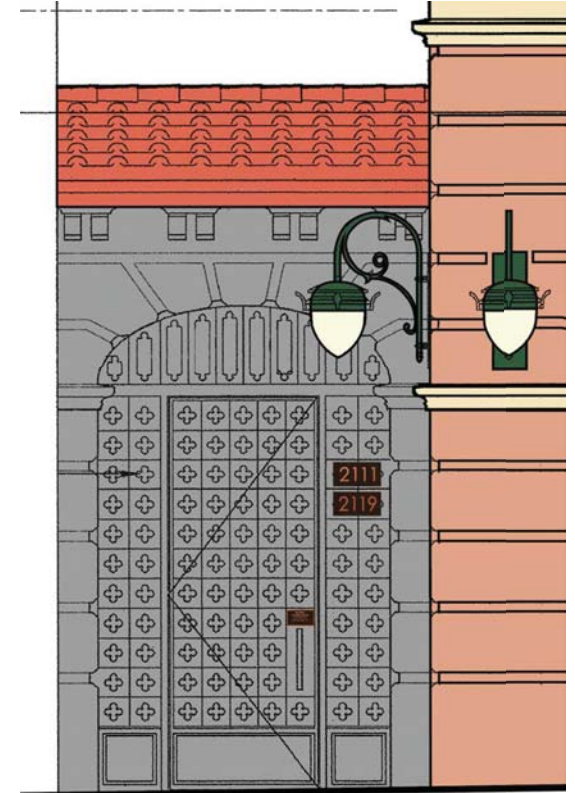
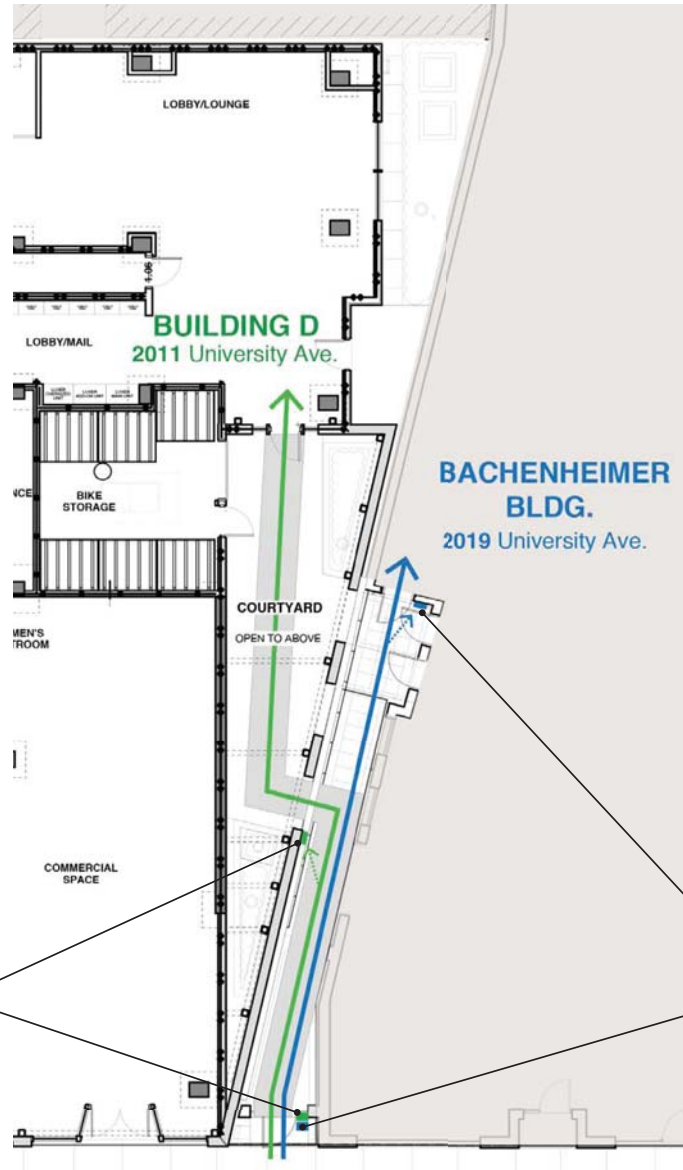

Thank you

Appendix

Downtown Berkeley Design Guidelines

SIGNS & GRAPHICS

- ALL SIGNS
- WALL SIGNS
Single-faced signs affixed directly to a building
- PROJECTING SIGNS
Signs which project from and are supported by a building, usually at a perpendicular angle
- WINDOW SIGNS
Signs on or behind windows
- AWNING, CANOPY, OR MARQUEE SIGNS
- MURALS
- SIGN BANNERS
- SIGNS ON TALLER BUILDINGS

SIGNS & GRAPHICS

Signs are an extremely visible part of the streetscape, and should reflect the quality of goods and services being offered Downtown. They should communicate an image of excellence, distinctive craftsmanship, and creativity, and should reinforce the unique and historic character to Downtown.

ALL SIGNS

- 1 Sign design and permit approval must be obtained prior to fabrication and installation of the sign.
- 2 Signs should reflect the character of the building and its use. When the building has little or no architectural character, it is imperative that the sign design adds interest and beauty to the façade.
- 3 Respect the immediate context of the building's location, and the historic character of Downtown.
- 4 The architecture of the building often identifies specific locations for signs, and these locations should be used.
- 5 Signs should be an integral part of the design of storefront alterations and new construction. Signs should not obscure architectural elements such as transoms or columns, nor appear cluttered.
- 6 The size of signs and sign letters should be in scale and proportional to the space in which they are located, with letters typically between 6 and 16 inches high.
- 7 Sign letter and materials should be professionally designed and fabricated.
- 8 Primary signs should contain only the name of the business and/or its logo. Secondary text which identifies products should be located in a secondary location.
- 9 Locate signs for ground floor tenants at storefront level. Signs on the upper façade should be building identification signs only.
- 10 Construct signs using high-quality materials such as metal, stone, wood, gold leaf, and exposed



Figure 31: Wall signs should be an integral part of storefront designs, and should fit within or just above the enframed storefront. In both the above examples, the size and placement of the signs not only respect the composition of the building, but are also at a suitable scale for a pedestrian-oriented district.

SIGNS & GRAPHICS (CONTINUED)

neon. Signs should be a matte finish so as to not cause glare. Internally lit plastic letters or signs are strongly discouraged.

- 11 Firmly anchor the sign to the building in a way that does not damage the surface, and allows for easy removal to accommodate the changing tenants.
- 12 Coordinate the design and alignment of signs on multiple use buildings in order to achieve a unified appearance rather than visual confusion.
- 13 Retain historic signs and inscriptions, and do not remove or replant historic ghost signs. If it is necessary to remove or relocate historic signs, store them on the premises for future reuse.
- 14 On Landmark buildings, signs should be designed and located to be consistent with the character of the building and the era in which the building was constructed.
- 15 Modify historic signs for new use only to the extent that the changes are compatible with the original sign. Modifications should have the ability to be re-

moved without affecting original elements, in anticipation of future restoration.

- 16 Modify corporate logo signs to conform to these guidelines, if necessary.
- 17 Cabinet signs are strongly discouraged; if used on existing, permitted signs, illuminate only the individual lettering or symbols, not the entire sign face.
- 18 Sign lighting, if any, should utilize spot-lighting, halo lighting, or exposed neon. Spot lighting should be inconspicuous or an integral design feature of the sign, and should not cause glare for pedestrians or motorists. Do not use sign lighting which blinks or flashes.
- 19 In addition to these guidelines, all signs must conform to the City of Berkeley Sign Ordinance. Design approval and sign permit must be obtained prior to sign fabrication.
- 20 Temporary signs should use high-quality graphics and must be removed within 30 days.



Figure 32: Exposed neon is encouraged as a means of sign illumination.

SIGNS & GRAPHICS (CONTINUED)

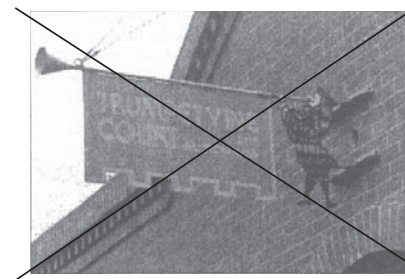

Figure 33: Symbol or icon signs provide added visual interest.



Figure 34: Window sign allowing clear visibility into store.

WALL SIGNS

- 1 Locate wall signs on the upper portion of the storefront, within or just above the enframed storefront opening. The length of the sign should not exceed the width of the enframed storefront.
- 2 Design signs which are compatible with the storefront in scale, proportions, and color.
- 3 Cabinet signs are strongly discouraged.
- 4 Maximum heights should generally not exceed 2 feet, with characters between 6 and 16 inches high. Signs should project no more than 9 inches from the building's face.

PROJECTING SIGNS

- 1 Design and locate signs which are compatible in scale, proportion and design with the façade. Rectangular signs should typically be vertically oriented and of minimal size (under 12 square feet per face)
- 2 Symbol or icon signs are preferable to worded projecting signs because they add visual interest to the street.
- 3 Do not locate projecting signs on the upper façade unless clear historical evidence of their use exists.

Locate projecting signs over pedestrian rights-of-way, not public streets.

- 4 Mount projecting business signs perpendicular to the façade of the building, and at least 8 feet above the sidewalk. The outside edge must be at least 1.5 feet from the curb line, and no more than 5 feet from the face of the building.
- 5 Mounting hardware should be an attractive and integral part of the sign design.

WINDOW SIGNS

- 1 Storefront window signs encourage pedestrian interest. Window signs should not exceed 15% of the window area so that visibility into and out of the window is not obstructed.
- 2 Use high-quality materials and techniques such as paint, gold-leaf, neon, and sandblasted or etched glass.
- 3 Apply window signs directly to the interior face of the glazing, or hang signs inside the window. Cancel all mounting of hardware and equipment.
- 4 Use high-quality graphics for temporary wall signs and advertisements. These must be removed after 30 days.

SIGNS & GRAPHICS (CONTINUED)



Figure 35: Awning signs should be limited to vertical surfaces.

AWNING, CANOPY OR MARQUEE SIGNS

- 1 Locate signs only on the vertical surfaces of awnings and canopies. The height of the characters should be less than 65% of the height of these vertical surfaces. On some canopies, it may be appropriate to locate letters above the top edge.
- 2 Product signs are not allowed on the front of the valance or canopy. Secondary text should be reserved for awning returns and canopy ends.
- 3 Install new marquee signs only on buildings occupied by theatres (film and live), concert and recital halls.

MURALS

- 1 Locate murals only on blank walls, security doors, or temporary areas such as construction fencing.
- 2 Murals which contain advertising are prohibited.
- 3 Mural subjects should not be threatening or intimidating to people.

SIGN BANNERS

- 1 Cloth banners can help to add interest and color to blank facades and special buildings. They should typically be vertically oriented and compatible with the overall character and color of the building.
- 2 Banners should look like architectural elements of the building, not flags, and should be attached at the top and bottom.
- 3 Banners which include text are also signs, and guidelines for All Signs and Projecting Signs also apply.
- 4 Banners should be at least 8 feet above the sidewalk, at least 1.5 feet from the curb line, and should project no more than 3 feet from the building façade.
- 5 Use canvas rather than vinyl, plastic, metal or other materials.
- 6 Temporary signs should use high-quality graphics and must be removed within 30 days.

SIGNS ON TALLER BUILDINGS

Architecture, not advertising, should define the upper elevations of buildings, especially those visible from beyond the Downtown. Commercial signage, advertising signage (including emblems or logos) or building name signage should be avoided on adjacent to the roofs of buildings in Downtown.

NOTE: DRC considered whether signage should be limited to below a certain height to avoid the “commercialization of Berkeley’s skyline.” No recommendation was made.

City Ordinance

Building Sign
Storefront Sign
Awning
Blade Sign
Window Sign

REGULATIONS GENERALLY (Chapter 20.16)

20.16.010 Prohibited signs--Exceptions.

A. No sign, poster, placard, card, sticker, banner, or other device calculated to attract attention of the public shall be posted, printed, stamped, stuck or otherwise affixed to or placed upon any public sidewalk, crosswalk, median strip, curb, lamppost, hydrant, tree, utility pole, any fixture of the traffic control, fire alarm or police alarm system of the City, except:

1. Legal notices that are authorized by law to be so located and messages placed on bus shelters sponsored or contracted by AC Transit pursuant to a contract with AC Transit and with its consent;
 2. Portable signs as permitted by Section 20.16.180; and
 3. Temporary signs concerning noncommercial events in the form of posters, placards, cards, stickers, or flyers that do not cause a hazard to pedestrian or vehicle traffic, and that are affixed to City-owned utility pole and lampposts in a manner consistent with standards promulgated by the Department of Public Works.
- B. No sign shall be located at or near any street intersection or any street and driveway intersection so as to create a traffic hazard by obstructing vision. No sign shall be located, constructed or lighted so as to interfere with, obstruct the view of or be confused with any authorized traffic sign, signal or device.
- C. The following types of signs are prohibited:
1. Off-premises signs west of the western line of Third Street that are designed to have the message thereon viewed primarily from the Eastshore Freeway, unless permitted by a relocation agreement pursuant to Section 20.04.040;
 2. Off-premises signs that are designed or intended to be visible primarily from any residential district or any public park, square, or plaza;
 3. Pole signs;
 4. Ground signs more than twenty (20) feet in height;
 5. Wind signs;
 6. Signs attached to or painted on an inoperable and unlicensed vehicle, motorized or non-motorized, that is located in view of the right-of-way; and
 7. Signs of any type above the third floor space, or forty (40) feet above the existing grade adjacent to the building, whichever is less, in any commercial district. (Ord. 7577-NS § 2, 2017; Ord. 7447-NS § 1, 2015; Ord. 7120-NS § 8 (part), 2009)

20.16.020 Clearance requirements.

Signs shall be so located as to maintain the clearances from overhead power, service, and communication lines as required by the Public Utilities Commission of the state and in no event shall be located with less than six feet horizontal and twelve (12) feet vertical clearance from electric conductors, bare or insulated, installed above the ground which are energized in excess of seven hundred fifty (750) volts, except such conductors as are enclosed in iron pipe or other metal covering of equal strength. (Ord. 7120-NS § 8 (part), 2009)

20.16.030 Measuring sign area and sign height.

- A. The sign area of a sign with no clearly defined border is the area within the perimeter of a rectangle, triangle or circle which would enclose such sign or which would enclose letters, shapes or words of whatever shape.
- B. The sign area of a multi-sided sign is the sum of the sign area of each side.
- C. The sign area of a sphere is forty (40) percent of the surface area of the sphere.
- D. The height of a sign is the vertical distance from the uppermost point used in measuring sign area to the existing grade immediately below the sign. Sign height shall be measured from the bottom of the base of the sign or the top of the nearest curb of the street on which the sign fronts, whichever measurement is the greatest. (Ord. 7120-NS § 8 (part), 2009)

20.16.040 Obstructing certain areas or facilities prohibited.

No sign or sign structure shall be erected in such manner that any portion thereof will interfere with the free use of any fire escape, exit or standpipe, or will obstruct, block or cover any window, except window signs as defined in Section 20.08.260, and as permitted in Section 20.16.160. (Ord. 7120-NS § 8 (part), 2009)

20.16.040 20.16.050 Awnings--On-premises signs.

- A. On-premises signs may be attached to or painted upon the vertical edges of awnings; provided, that such signs do not extend beyond the exterior limits of such edges.
- B. On-premises signs may be attached to or painted upon the front sloping or nonvertical portion of awnings if the vertical portion of the awning is less than nine inches in height; provided, that the sign area does not exceed twenty (20) percent of the area of such sloping or nonvertical portion, or three hundred twenty-five (325) square feet, whichever is less. In such cases, no signage may be installed on the vertical portion of the awning. (Ord. 7120-NS § 8 (part), 2009)

City Ordinance - con't

20.16.070 Business complex signs.

A. A business located within an enclosed business complex, such as a shopping mall; arcade; multistory dental, medical, business or office building; or similar structure, and which does not have frontage visible from a public street or way, may display signs upon the exterior of said structure where it abuts upon a public street, but in no case shall the number and total area of such signs exceed that permitted for the business complex as a single premises as specified by Chapter 20.24 of this code. For a business complex structure in which the allowable sign area is shared by four or more businesses, an exception to the number of signs and the total areas is permitted subject to the following standards:

1. One additional wall sign, projecting sign or ground sign shall be permitted for each street frontage of the business complex structure.
2. The maximum area of such sign(s) shall not exceed that already specified by this code for its type and location.
3. No sign of any type shall be suspended from or attached to the face of a multistory building above the third floor space, or forty (40) feet above the existing grade adjacent to the building, whichever is less.

B. A business located within a business complex, such as a shopping mall, arcade or similar structure, which has frontage visible from a public street may display signs upon the exterior of the single business premises that abuts upon a public street(s), but in no case shall the number and total area of such signs exceed that specified by Chapter 20.24 of this code with the following exceptions:

1. Each premises may have an individual ground sign as specified in Chapter 20.24 of this code, provided said ground sign is located directly in front of said premises; or
2. Each premises may share a common ground sign; provided, that the total aggregate area of such common ground sign does not exceed that permitted for the business complex as a single premises. (Ord. 7120-NS § 8 (part), 2009)

20.16.080 Ground signs.

A. No portion of a ground sign shall be higher than twenty (20) feet above existing grade.

B. A ground sign may project up to five feet over the public right-of-way; provided, that no portion of the sign is lower than twelve (12) feet above the surface of the street or sidewalk or closer than one foot to the curbline.

However, a ground sign may not project over the public right-of-way if it is located on premises on which there is another projecting sign or a marquee sign that projects over the public right-of-way. (Ord. 7120-NS § 8 (part), 2009)

20.16.110 Marquee signs.

A. Marquee signs may be located on any edge or on the top of the marquee edge and parallel therewith;

provided, that signs located on the top of the marquee edge shall not exceed five feet in height.

B. No portion of a marquee sign shall be higher than the eave line or parapet wall of a building. No portion of a marquee sign shall be above the third floor space, or forty (40) feet above the existing grade adjacent to the building, whichever is less, in any commercial district.

C. The total sign area of marquee signs shall not exceed twenty (20) percent of the building face or three hundred twenty-five (325) square feet, whichever is less. As used in this section, "building face" means the product in square feet of the frontage of the building premises and the exterior height of the building premises.

D. Notwithstanding the requirements of Section 20.16.130, a marquee sign that conforms to the requirements of this section may extend more than five feet from the building wall into the public right-of-way but no closer than one foot from the curb line. (Ord. 7577-NS § 3, 2017; Ord. 7120-NS § 8 (part), 2009)

20.16.130 Projecting signs.

A. A sign may project horizontally from the exterior wall of a building; provided, that such projection does not violate other sections of this chapter or interfere with the allowable signs permitted on the premises being encroached upon. As used in this section, projecting signs shall not be construed to be off-premises signs.

B. Maximum Projection. No portion of a projecting sign shall extend more than five feet from the building wall into the public right-of-way or closer than one foot from the curb line, whichever is less. In no case shall any portion of a projecting sign extend closer than three feet to a utility pole.

C. Height. The height of a projecting sign shall not exceed twenty-five (25) percent of the height of the building wall to which it is attached. No portion of a projecting sign shall extend more than one-third of the sign height or eight feet, whichever is less, above the highest point of a parapet wall or more than four feet above an eave line. The lowest point of the sign must be at least eight feet above the surface of any sidewalk or street. No portion of a projecting sign shall extend above the third floor space, or forty (40) feet above the existing grade adjacent to the building, whichever is less.

D. Thickness. The thickness of a projecting sign shall not exceed two feet.

E. A projecting sign shall not interfere with views of traffic control devices or signs or be designed or located so as to cause harm to street trees. (Ord. 7577-NS § 4, 2017; Ord. 7120-NS § 8 (part), 2009)

Section 20.16.150 Wall signs.

Wall signs shall comply with the following standards:

A. Height. No portion of a wall sign shall be higher than the roof of a building or lower than three feet above existing ground level. No portion of a wall sign shall be permitted above the third floor space, or forty (40) feet above the existing grade adjacent to the building, whichever is less.

City Ordinance - con't

B. Maximum Projection.

1. When the lower edge of a wall sign is between three feet and ten (10) feet above existing grade, no portion of the sign shall project more than four inches from the wall of the building.
2. When the lower edge of a wall sign is more than ten (10) feet above existing grade, no portion of the sign shall project more than twelve (12) inches from the wall of the building. (Ord. 7577-NS § 6, 2017; Ord. 7120-NS § 8 (part), 2009)

20.16.160 Window signs.

The sign area of window signs, permanent and temporary, shall not exceed fifteen (15) percent of the window area of the building premises or three hundred (300) square feet, whichever is less. Subject to the window area limitation herein specified, temporary window signs may be in addition to the signs otherwise permitted on the premises. For the purpose of determining allowable sign area on any premises, permanent window signs shall be treated as wall signs. (Ord. 7120-NS § 8 (part), 2009)

20.16.170 Shingle sign.

Under the following conditions, a premises with a marquee, covered walkway or canopy may suspend beneath the marquee, covered walkway or canopy one shingle sign in addition to other permitted signs:

- A. The sign area shall be debited against the allowable wall sign area for the premises and shall not exceed three hundred (300) square inches for a single face area;
- B. The clearance of the sign above grade shall be not less than eight feet;
- C. The sign must be on premises; and
- D. The sign shall not be illuminated. (Ord. 7120-NS § 8 (part), 2009)

20.16.180 Portable signs permitted on public property--Conditions.

Portable signs shall be permitted on sidewalks and median strips during the first two Saturdays and Sundays of May and during every Saturday and Sunday between Thanksgiving Day and Christmas Day if all of the following conditions are met:

- A. The portable sign is located in the area bounded by Sacramento Street, Gilman Street, the Eastshore Freeway, and Ashby Avenue. The City Council finds and declares that portable signs on sidewalks and median strips in this area are less likely to interfere with pedestrian traffic than in other parts of the City in which there is generally more foot traffic.

COMMERCIAL DISTRICT REGULATIONS (Chapter 20.24)

Section 20.24.010 Scope of regulations.

Except as provided in this chapter, Chapter 20.16 and Chapter 20.36, no sign shall be permitted on private property in any commercial district. (Ord. 7120-NS § 10 (part), 2009; Ord. 6424-NS § 1 (part), 1998)

Section 20.24.020 C-1, C-2 and C-3 district signs.

The following signs shall be permitted on premises in C-1, C-2 and C-3 districts:

A. On-premises signs as set forth in Section 20.24.030;

B. Up to two temporary signs as follows:

1. One ground or wall sign not exceeding twenty-four (24) square feet in sign area, no portion of which is higher than ten (10) feet above existing grade; and
2. One ground or wall sign not exceeding thirty-two (32) square feet in area, no portion of which is higher than twenty (20) feet above existing grade. (Ord. 7120-NS § 10 (part), 2009; Ord. 6424-NS § 1 (part), 1998)

20.24.030 Number of on-premises signs permitted on premises

In addition to temporary signs, the number of on-premises signs on premises in commercial districts is limited to:

- A. On premises with one street frontage, any combination of two of the following: one wall sign, one projecting sign, one ground sign, one roof sign, one marquee sign, one moving sign.
- B. On premises with more than one street frontage, for each additional street frontage any combination of two of the following: one wall sign, one projecting sign, one marquee sign, one moving sign.
- C. An unlimited number of on-premises signs with a sign area of eight square feet or less within the business premises, to direct customers of the business within the business premises. (Ord. 7120-NS § 10 (part), 2009; Ord. 6424-NS § 1 (part), 1998)

20.24.040 On-premises signs--Allowable sign area limitations.

Except as otherwise provided in Section 20.24.050 and Chapter 20.36, the allowable sign area of onpremises signs in commercial districts shall be subject to the provisions of Chapter 20.16 and the following limitations:

- A. The sign area of ground signs shall be limited to one square foot for each linear foot of street frontage of the premises or two hundred (200) square feet, whichever is less;
- B. The sign area of projecting signs shall not exceed ten (10) percent of the building face of the premises

City Ordinance - con't

or one hundred fifty (150) square feet, whichever is less;

C. The sign area of wall signs shall not exceed fifteen (15) percent of the building face of the premises or one hundred fifty (150) square feet, whichever is less;

D. The sign area of roof signs shall not exceed ten (10) percent of the building face of the premises or one hundred (100) square feet, whichever is less;

E. The area of on-premises signs permitted under Section 20.24.030.C shall not be counted against the allowable sign area of on-premises signs;

F. As used in this section, "building face" means the product in square feet of the frontage of the building premises and the exterior height of the building premises. (Ord. 7120-NS § 10 (part), 2009; Ord. 6474-NS § 21, 1999; Ord. 6424-NS § 1 (part), 1998)

Section 20.24.050 Signs on premises across street from R district.

On premises situated directly across a street from an R district, the following limitations and prohibitions shall apply:

A. The total sign area for any such premises shall not exceed sixty (60) square feet;

B. No sign shall be directly illuminated, flashing, or located in a required yard area, and no moving sign shall be illuminated. (Ord. 7120-NS § 10 (part), 2009; Ord. 6424-NS § 1 (part), 1998)

Official Zoning Map

of the
City of Berkeley, California

Adopted by the Berkeley City Council on
March 18, 1999 - Ordinance No. 6478-N.S.

ZONING DISTRICTS

R-1	Single Family Residential
R-1A	Limited Two-family Residential
R-2	Restricted Two-family Residential
R-2A	Restricted Multiple-family Residential
R-3	Multiple-family Residential
R-4	Multi-family Residential
R-5	High Density Residential
ES-R	Environmental Safety-Residential
R-S	Residential High Density Subarea
R-SMU	Residential Mixed Use Subarea
C-DMU	C-DMU Core
C-DMU	C-DMU Outer Core
C-DMU	C-DMU Corridor
C-DMU	C-DMU Buffer
C-1	General Commercial
C-E	Elmwood Commercial
C-N	Neighborhood Commercial
C-NS	North Shattuck Commercial
C-SA	South Area Commercial
C-SO	Solano Avenue Commercial
C-T	Telegraph Avenue Commercial
C-W	West Berkeley Commercial
M	Manufacturing
MM	Mixed Manufacturing
MULI	Mixed Use-Light Industrial
MUR	Mixed Use-Residential
SP	Specific Plan
U	Unclassified

OTHER MAP SYMBOLS

	Hillside Overlay Boundary
	Arts District Overlay
	Southside Plan
	Downtown Area Plan
University Ave Strategic Plan	
	Avenue Mixed Use
	UASP Node

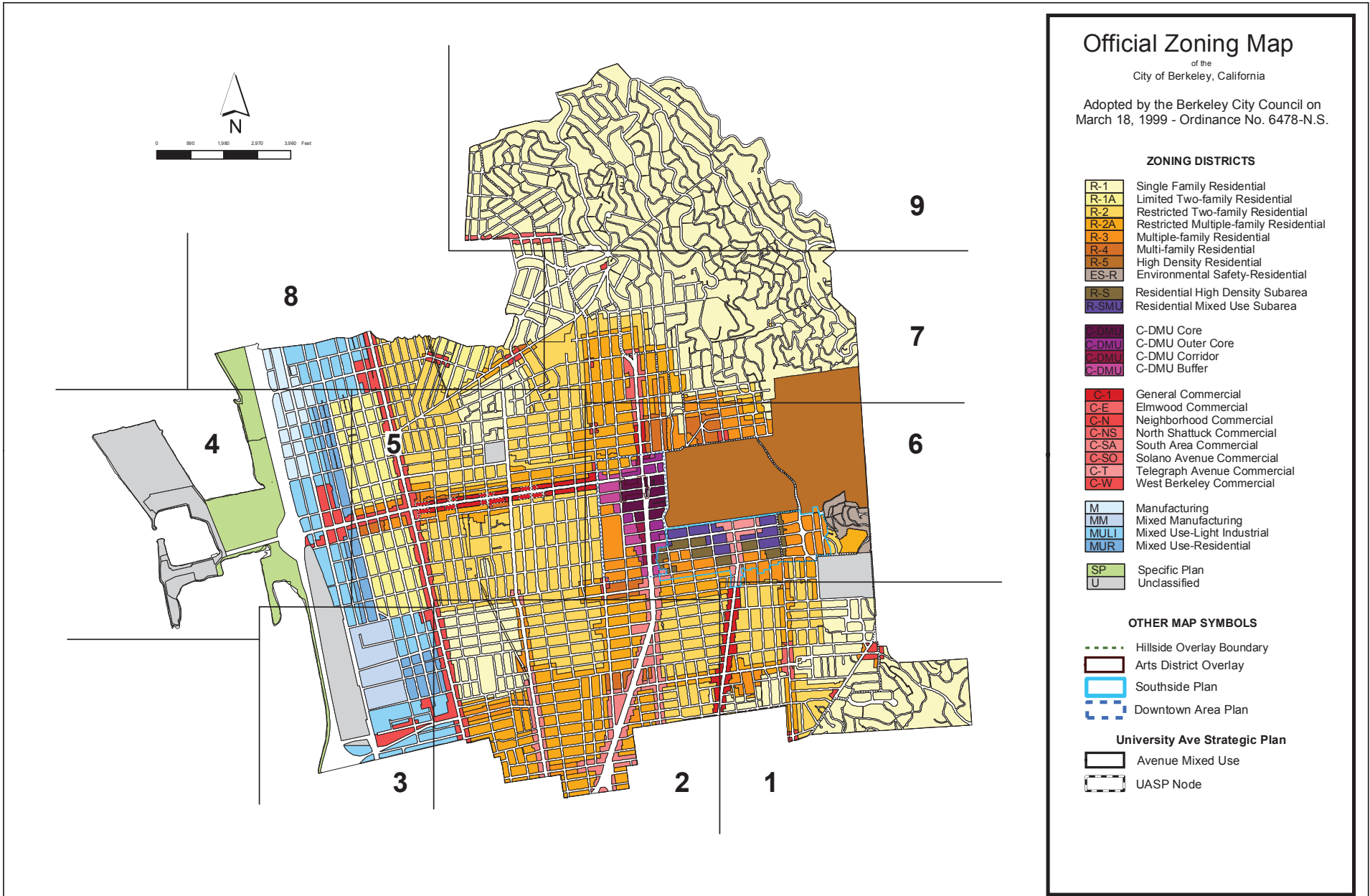

7

Official Zoning Map

of the
City of Berkeley, California

Ordinance Number	Ordinance Effective Date	Zoning Districts Affected
6514-N.S.	December 16, 1999	C-2
7211-N.S.	November 12, 2011	R-S, R-SMU
7232-N.S.	May 5, 2012	C-DMU

0 500 1,000 Feet

Scale = 1:7,500



6

5

2

1

